



# LEVANTÉ®

ALUMINUM ARCHITECTURAL COMPONENTS

**LEVANTÉ®, LLC**  
901 NORTHVIEW ROAD  
SUITE 100  
WAUKESHA, WISCONSIN 53188

Project Name:

Part Name:

FINISHING TRIM

Used on assembly:

Part No.:

LDCF219

Drawing Number:

AL-13619-B

### REVISIONS

REV.	DESCRIPTION	DATE	APPROVED
B	RADIUS OF UPPER SECTION HAS BEEN REDUCED FROM R0.394" [10.00mm] TO R0.161" [4.10mm]. WIDTH OF TOP HORIZONTAL SECTION HAS BEEN REDUCED FROM 2.165" [55.00mm] TO 1.772" [45.00mm] AS PER CUSTOMER'S REVISION NOTES.	6/22/2020	EASS

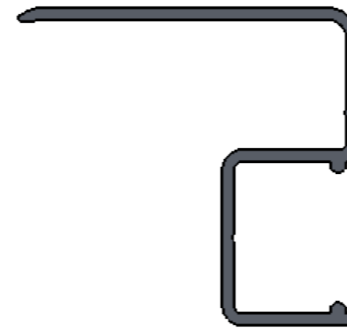

EXTRUSION PROFILE  
SCALE 1:1

NOTES:

1. EXTRUSION SHALL BE STRAIGHT WITHIN 1.1mm PER 1M [0.015"/FOOT]
2. EXTRUSION TWIST 1.0DEG PER 1M [1.0DEG/FOOT]
3. EXTRUSION CROSS SECTIONAL AREA IS 0.2923 sq.in. [188.58 mm sq.]
4. ALL RADII & FILLET RADIUS TO BE R0.016" [0.40mm] UNLESS OTHERWISE SPECIFIED
5. SECTIONAL MATERIAL THICKNESS 0.063"±0.006" [1.60mm±0.15mm] UNLESS OTHERWISE SPECIFIED
6. CRITICAL DIMENSIONS ARE SHOWN WITHIN ( )
7. REFERENCE DIMENSIONS ARE SHOWN WITHIN ( )
8. ALL DIMENSIONS ARE FINISHED PART DIMENSIONS
9. ALL DIMENSIONS AND TOLERANCES ARE TO BE INTERPRETED ACCORDING TO ASME Y14.

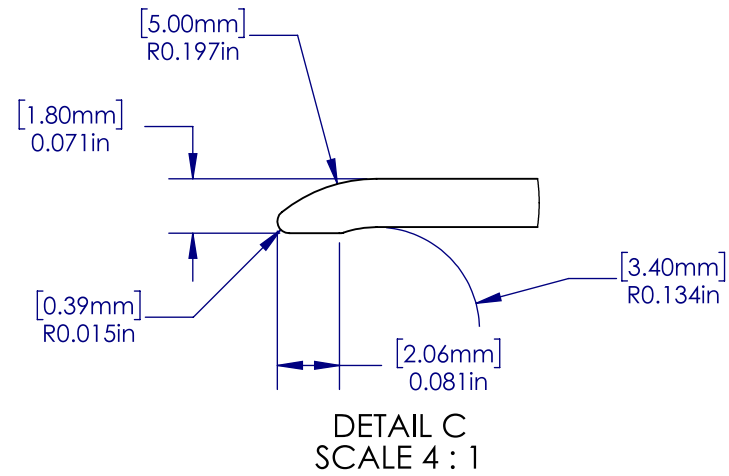
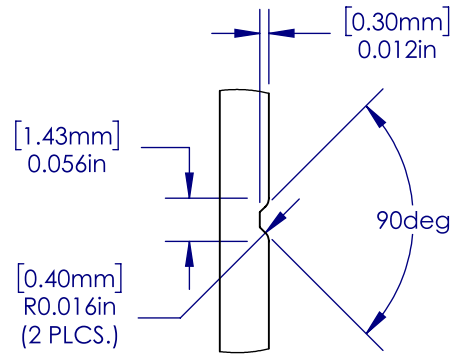
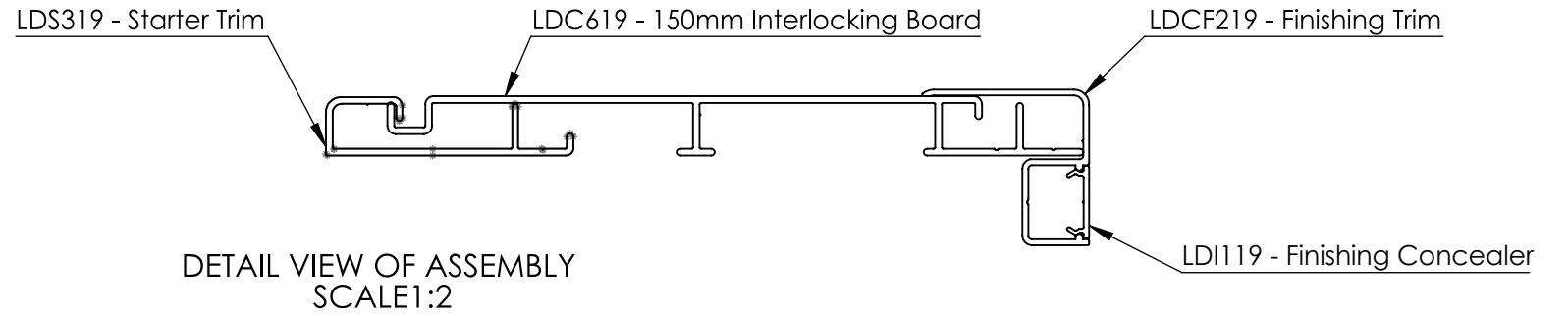

DETAIL B  
SCALE 4:1

DETAIL C  
SCALE 4:1

--- EXPOSED SURFACE

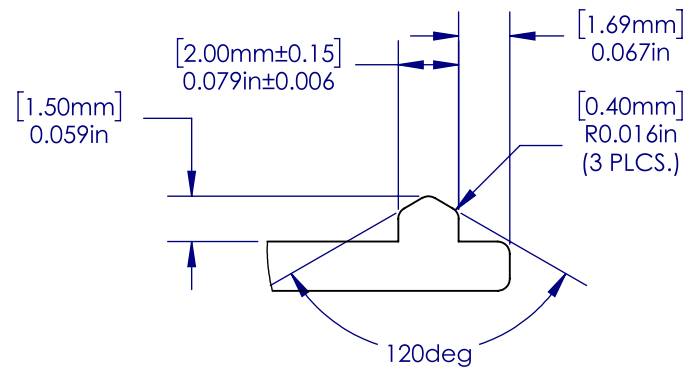
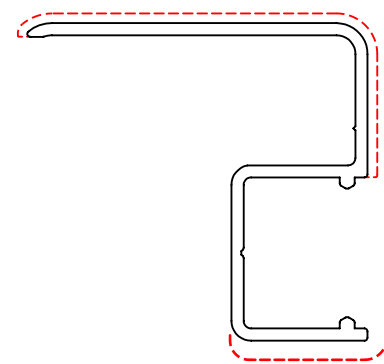

DETAIL A  
SCALE 4:1

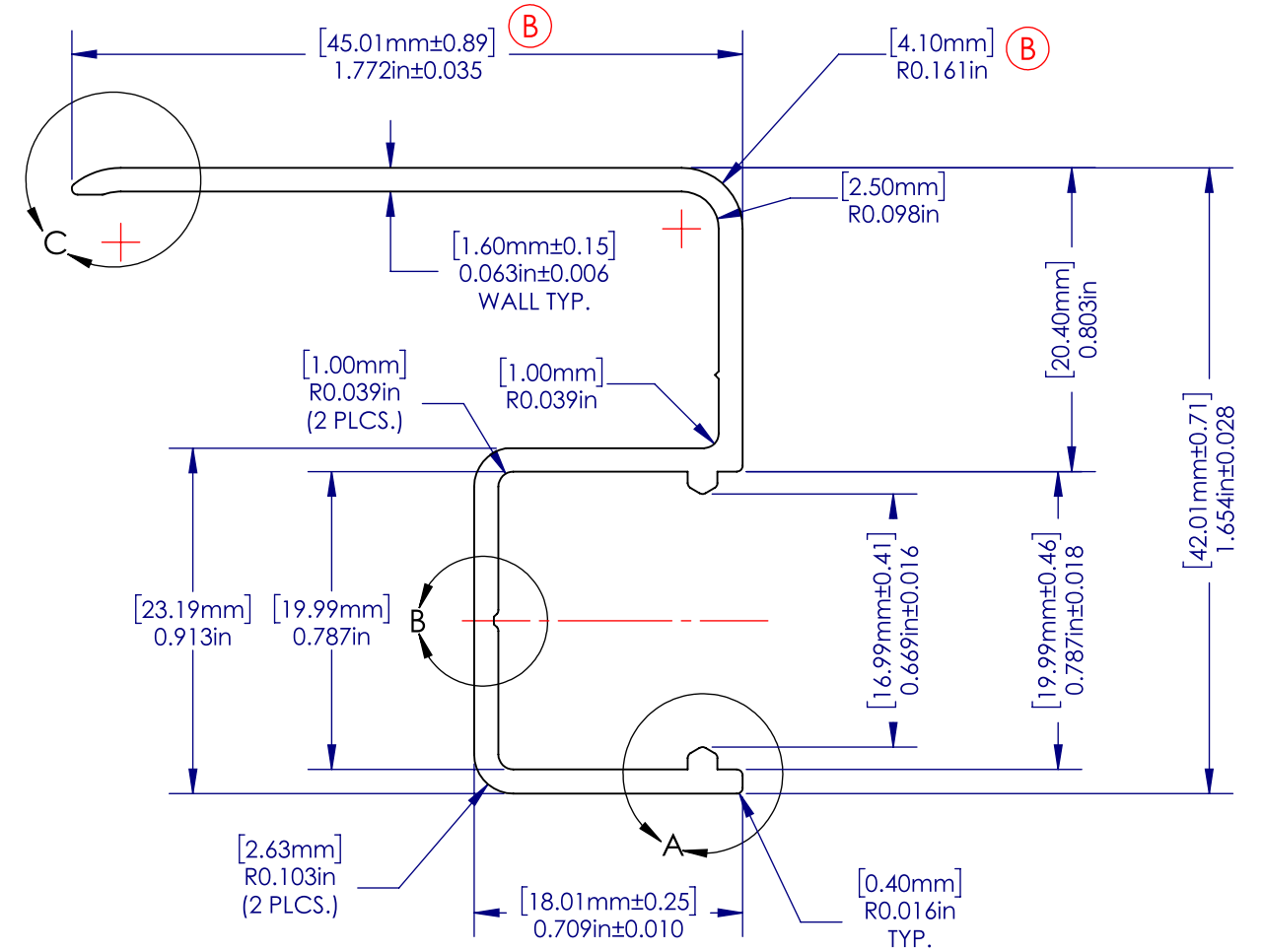

WEIGHT/LENGTH	0.515	kg/m	0.346	lbs./ft.
AREA	188.58	sq. mm	0.2923	sq. in.
TOTAL PERIMETER	235.84	mm	9.2850	in.
OUTSIDE PERIMETER	235.84	mm	9.2850	in.
EXPOSED PERIMETER	90.28	mm	3.5543	in.

(B)

PROPRIETARY AND CONFIDENTIAL  
THE INFORMATION CONTAINED IN THIS DRAWING IS THE SOLE PROPERTY OF ALWOOD LLC. ANY REPRODUCTION IN PART OR AS A WHOLE WITHOUT THE WRITTEN PERMISSION OF ALWOOD LLC IS PROHIBITED.

UNLESS OTHERWISE SPECIFIED: DIMENSIONS ARE IN INCHES [MM] TOLERANCES:		NAME	DATE	
MILLIMETERS	INCHES	EASS	06/22/20	
X = ±1	[.X = ±0.1]	DRAWN		TITLE:  <h2>Finishing Trim</h2>
.X = ±.25	[.XX = ±0.01]	CHECKED		
.XX = ±10	[.XXX = ±0.005]	ENG APPR.		
ANGLES	∠ = ± 1°	MFG APPR.		
FRACTIONS	X/X = ± 1/64	Q.A.		
INTERPRET GEOMETRIC TOLERANCING PER:	MATERIAL	COMMENTS:		SIZE PART NO. REV <b>B</b> LDCF219 <b>B</b>
6063-T5	FINISH			SCALE: 2:1 WEIGHT: 0.343 SHEET 2 OF 2
POWDER COAT	APPLICATION			