



LEVANTÉ[®]
ALUMINUM ARCHITECTURAL COMPONENTS

LEVANTÉ[®], LLC
901 NORTHVIEW ROAD
SUITE 100
WAUKESHA, WISCONSIN 53188

Project Name:

Part Name:

H TRIM BACK

Used on assembly:

Part No.:

LCBJ419

Drawing Number:

AL-13616-C

REVISIONS

REV.	DESCRIPTION	DATE	APPROVED
B	PROFILE'S WIDTH HAS BEEN MODIFIED FROM 3.937" [100.00mm] TO 2.756" [70.00mm] AS PER CUSTOMER'S REVISION NOTES.	6/26/2020	EASS
C	WIDTH HAS BEEN REDUCED FROM 2.756" [70.00mm] TO 2.500" [63.50mm]. DISTANCE FROM V-GROOVE TO VERTICAL WALL WAS REDUCED FROM 0.886" [22.50mm] TO 0.750" [19.05mm] AS PER CUSTOMER'S REVISION NOTES.	7/2/2020	EASS



EXTRUSION PROFILE
SCALE 1:1

NOTES:

1. EXTRUSION SHALL BE STRAIGHT WITHIN 1.1mm PER 1M [0.015"/FOOT]
2. EXTRUSION TWIST 1.0DEG PER 1M [1.0DEG/FOOT]
3. EXTRUSION CROSS SECTIONAL AREA IS 0.2189 sq.in. [141.24mm sq.]
4. ALL RADII & FILLET RADIUS TO BE R0.016" [0.41mm] UNLESS OTHERWISE SPECIFIED
5. SECTIONAL MATERIAL THICKNESS 0.059"±0.006" [1.50mm±0.15mm] UNLESS OTHERWISE SPECIFIED
6. CRITICAL DIMENSIONS ARE SHOWN WITHIN ()
7. REFERENCE DIMENSIONS ARE SHOWN WITHIN ()
8. ALL DIMENSIONS ARE FINISHED PART DIMENSIONS
9. ALL DIMENSIONS AND TOLERANCES ARE TO BE INTERPRETED ACCORDING TO ASME Y14.
10. SURFACE FINISH AS PER CUSTOMER'S PURCHASE ORDER

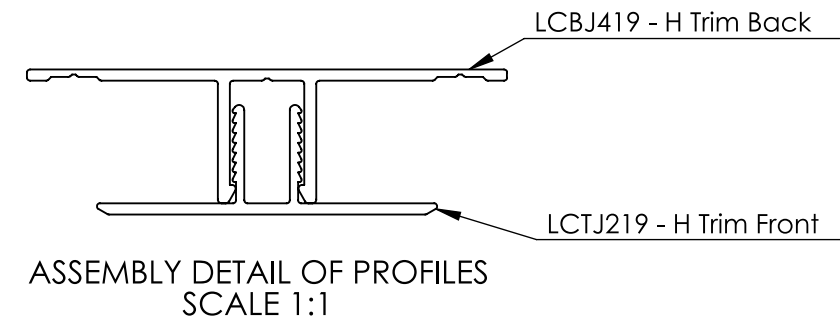
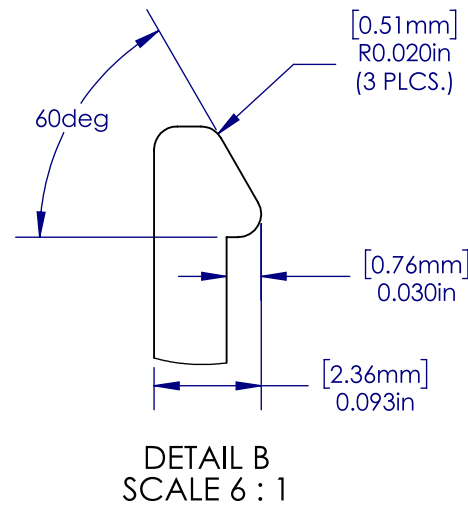
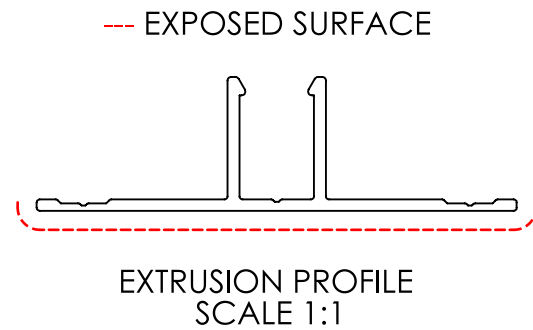
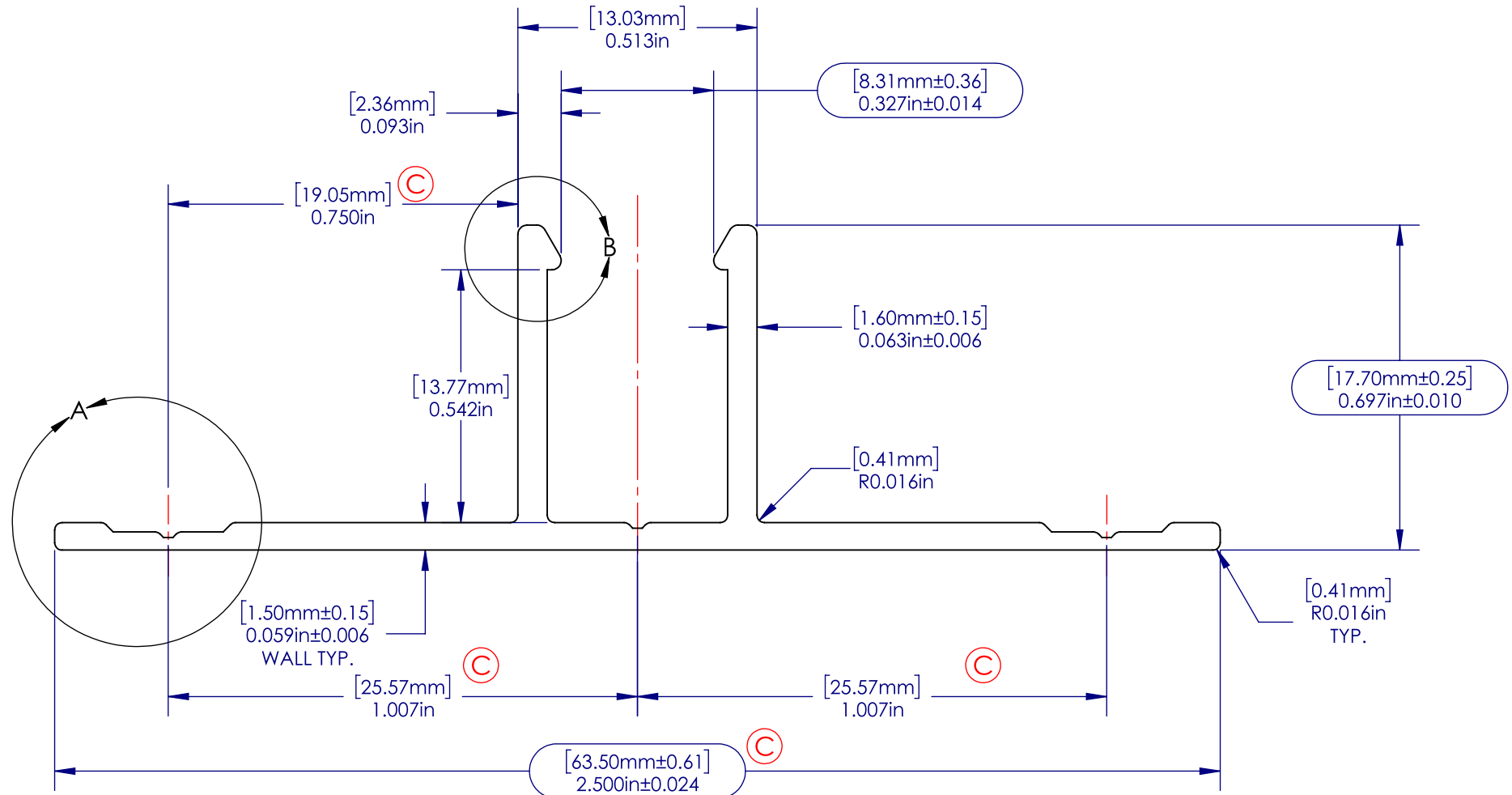
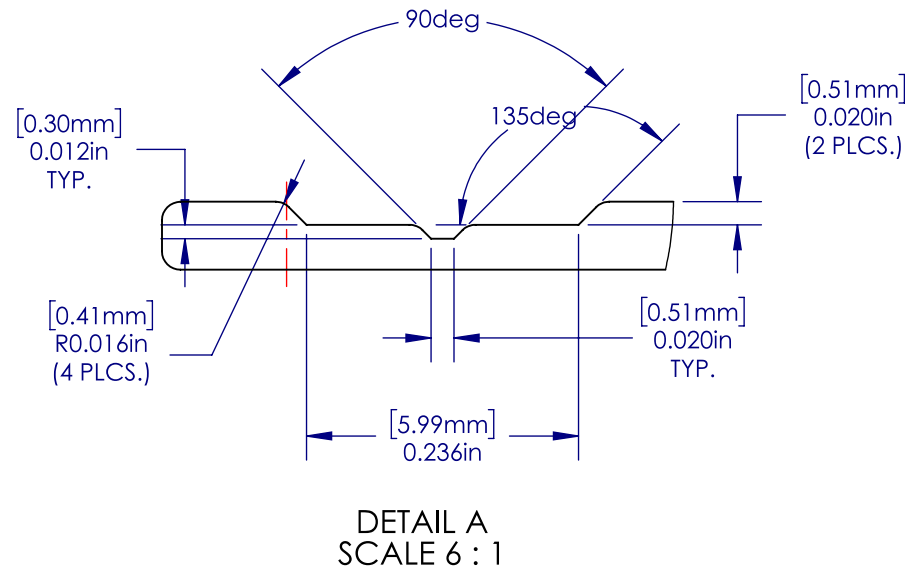

WEIGHT/LENGTH	0.386	kg/m	0.259	lbs./ft.
AREA	141.24	sq. mm	0.2189	sq. in.
TOTAL PERIMETER	195.38	mm	7.6923	in.
OUTSIDE PERIMETER	195.38	mm	7.6923	in.
EXPOSED PERIMETER	66.61	mm	2.6225	in.

PROPRIETARY AND CONFIDENTIAL
THE INFORMATION CONTAINED IN THIS DRAWING IS THE SOLE PROPERTY OF ALWOOD LLC. ANY REPRODUCTION IN PART OR AS A WHOLE WITHOUT THE WRITTEN PERMISSION OF ALWOOD LLC IS PROHIBITED.

UNLESS OTHERWISE SPECIFIED:	
DIMENSIONS ARE IN INCHES [MM]	
TOLERANCES:	
MILLIMETERS	INCHES
X = ±1	[.X = ±0.1]
.X = ±.25	[.XX = ±0.01]
.XX = ±10	[.XXX = ±0.005]
ANGLES	
∠ = ± 1°	
FRACTIONS	
X/X = ± 1/64	
INTERPRET GEOMETRIC TOLERANCING PER:	
MATERIAL	
6063-T5	
FINISH	
Powder Coat - Black	
NEXT ASSY	USED ON
APPLICATION	
DO NOT SCALE DRAWING	

NAME	DATE
EASS	07/02/20
DRAWN	
CHECKED	
ENG APPR.	
MFG APPR.	
Q.A.	
COMMENTS:	

LEVANTÉ
 ALUMINUM ARCHITECTURAL COMPONENTS

TITLE:
H Trim Back

SIZE	PART NO.	REV
B	LCBJ419	C

SCALE: 3:1 WEIGHT: 0.256 SHEET 2 OF 2