



LEVANTÉ®

ALUMINUM ARCHITECTURAL COMPONENTS

LEVANTÉ®, LLC
901 NORTHVIEW ROAD
SUITE 100
WAUKESHA, WISCONSIN 53188

Project Name:

Part Name:

OUTSIDE CORNER TRIM

Used on assembly:

Part No.:

LCFC119

Drawing Number:

AL-13613-C

REVISIONS

REV.	DESCRIPTION	DATE	APPROVED
B	FEMALE TABS HAVE BEEN EXTENDED AND TEETH HAVE BEEN ADDED TO CLIP FEATURE.	6/26/2020	EASS
C	FILLET RADIUS ON OUTER EDGE OF FEMALE TABS HAVE BEEN MODIFIED FROM 0.020" [0.51mm] TO 0.035" [0.89mm] TO INCREASED THE OVERALL STIFFNESS OF FEMALE TABS.	7/14/2020	EASS

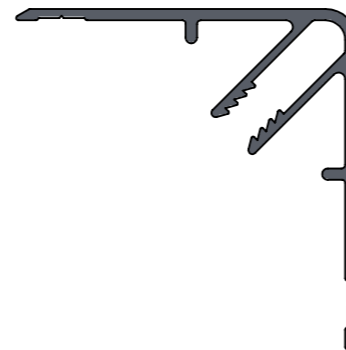

EXTRUSION PROFILE
SCALE 1:1

4

3

2

1

NOTES:

1. EXTRUSION SHALL BE STRAIGHT WITHIN 1.1mm PER 1M [0.015"/FOOT]
2. EXTRUSION TWIST 1.0DEG PER 1M [1.0DEG/FOOT]
3. EXTRUSION CROSS SECTIONAL AREA IS 0.2744 sq.in. [177.02mm sq.]
4. ALL RADII & FILLET RADIUS TO BE R0.012" [0.30mm] UNLESS OTHERWISE SPECIFIED
5. SECTIONAL MATERIAL THICKNESS 0.059"±0.006" [1.50mm±0.15mm] UNLESS OTHERWISE SPECIFIED
6. CRITICAL DIMENSIONS ARE SHOWN WITHIN \varnothing
7. REFERENCE DIMENSIONS ARE SHOWN WITHIN ()
8. ALL DIMENSIONS ARE FINISHED PART DIMENSIONS
9. ALL DIMENSIONS AND TOLERANCES ARE TO BE INTERPRETED ACCORDING TO ASME Y14.
10. SURFACE FINISH AS PER CUSTOMER'S PURCHASE ORDER

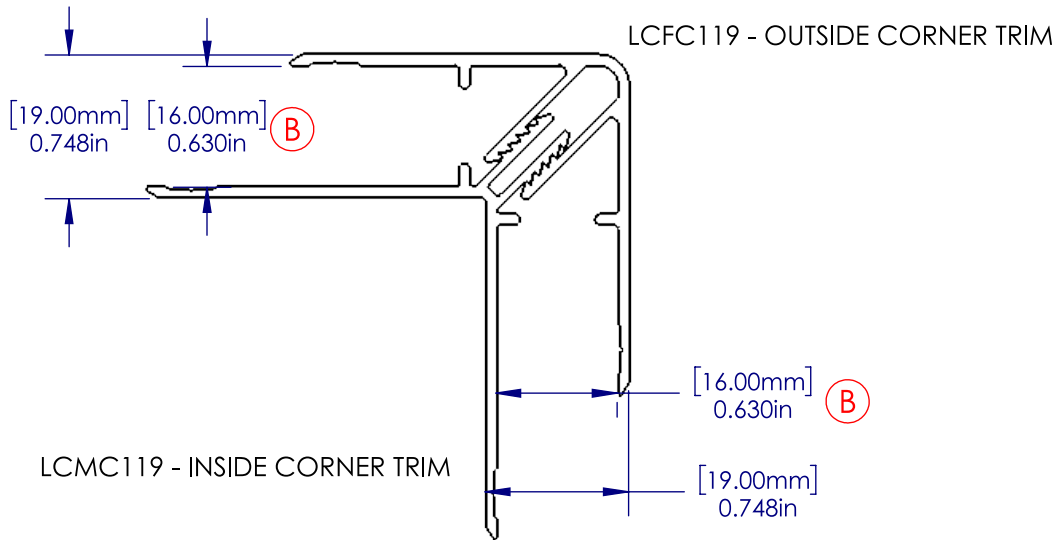

DETAIL VIEW OF ASSEMBLY SCALE 1:1

--- EXPOSED SURFACE

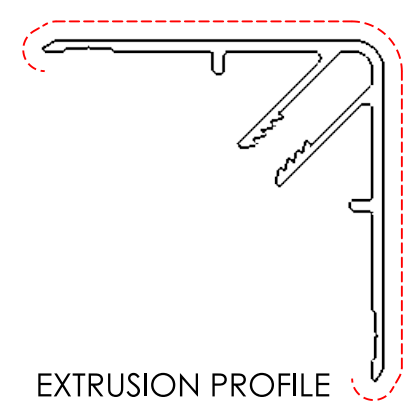

EXTRUSION PROFILE SCALE 1:1

WEIGHT/LENGTH	0.483	kg/m	0.325	lbs./ft.
AREA	177.02	sq. mm	0.2744	sq. in.
TOTAL PERIMETER	259.10	mm	10.2006	in.
OUTSIDE PERIMETER	259.10	mm	10.2006	in.
EXPOSED PERIMETER	89.86	mm	3.5379	in.

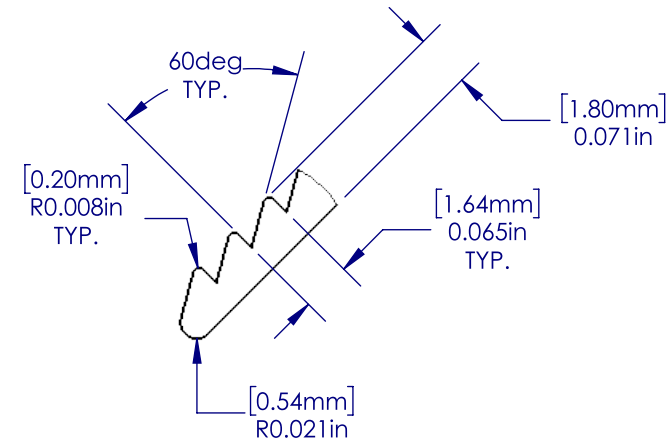
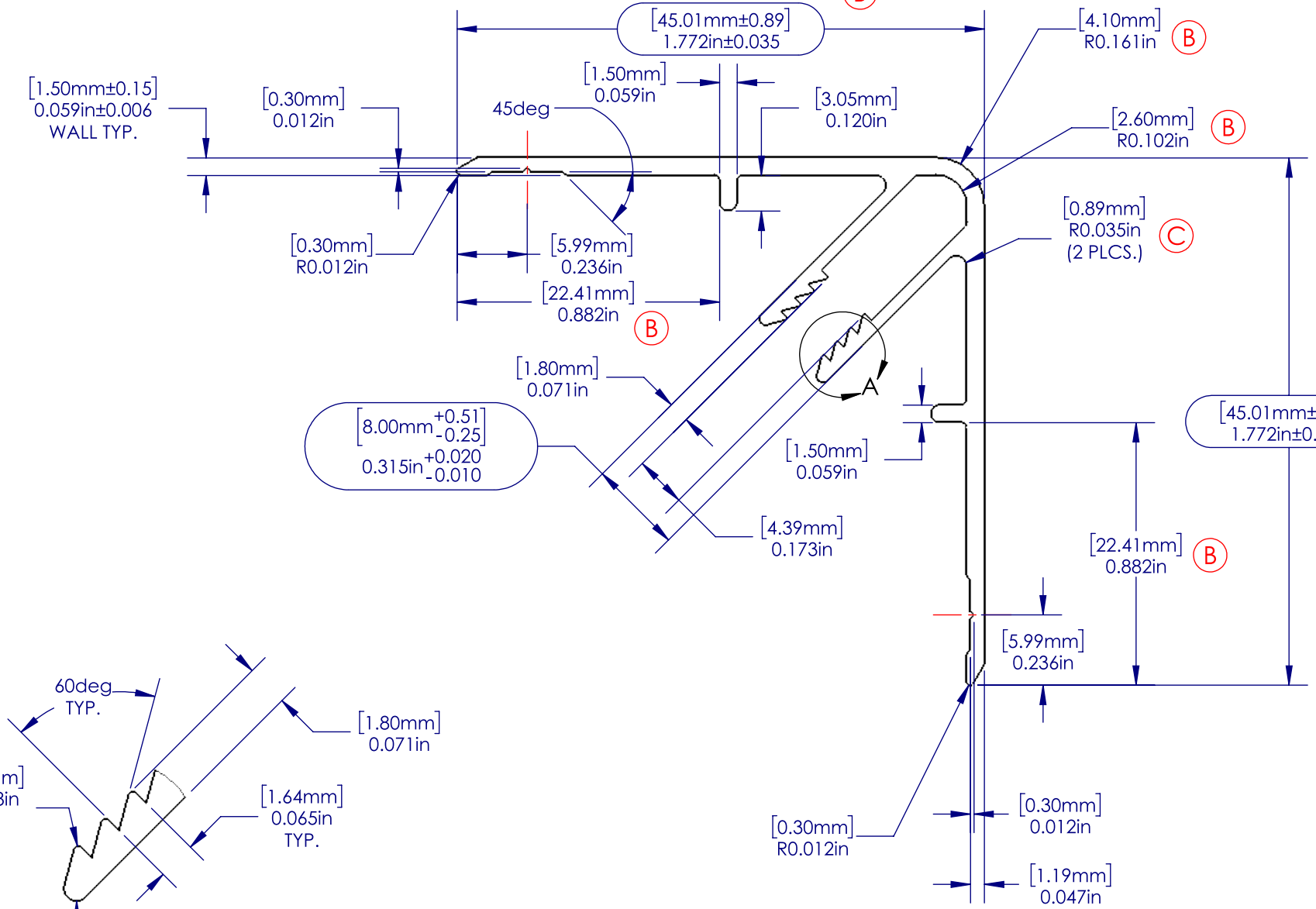

SCALE 4:1

PROPRIETARY AND CONFIDENTIAL
 THE INFORMATION CONTAINED IN THIS DRAWING IS THE SOLE PROPERTY OF ALWOOD LLC. ANY REPRODUCTION IN PART OR AS A WHOLE WITHOUT THE WRITTEN PERMISSION OF ALWOOD LLC IS PROHIBITED.

UNLESS OTHERWISE SPECIFIED: DIMENSIONS ARE IN INCHES [MM] TOLERANCES:		NAME	DATE
MILLIMETERS	INCHES	EASS	07/14/20
X = ±1	[.X = ±0.1]	DRAWN	
.X = ±.25	[.XX = ±0.01]	CHECKED	
.XX = ±10	[.XXX = ±0.005]	ENG APPR.	
ANGLES	∠ = ± 1°	MFG APPR.	
FRACTIONS	X/X = ± 1/64	Q.A.	
INTERPRET GEOMETRIC TOLERANCING PER:		COMMENTS:	
MATERIAL	6063-T5		
FINISH	Powder Coat		
NEXT ASSY	USED ON		
APPLICATION	DO NOT SCALE DRAWING		



TITLE:
Outside Corner Trim

SIZE	PART NO.	REV
B	LCFC119	C
SCALE: 2:1	WEIGHT: 2.634	SHEET 2 OF 2

4

3

2

1