



LEVANTÉ[®]
ALUMINUM ARCHITECTURAL COMPONENTS

LEVANTÉ[®], LLC
901 NORTHVIEW ROAD
SUITE 100
WAUKESHA, WISCONSIN 53188

Project Name:

Part Name:

H TRIM FRONT

Used on assembly:

Part No.:

LCTJ219

Drawing Number:

AL-13611-B

REVISIONS

REV.	DESCRIPTION	DATE	APPROVED
B	PROFILE'S WIDTH HAS BEEN REDUCED FROM 1.969" [50.00mm] TO 1.772" [45.00mm] AS PER CUSTOMER'S REVISION NOTES.	6/25/2020	EASS

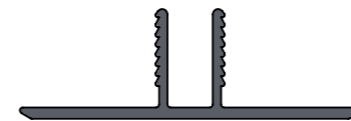

EXTRUSION PROFILE
SCALE 1:1

NOTES:

1. EXTRUSION SHALL BE STRAIGHT WITHIN 1.1mm PER 1M [0.015"/FOOT]
2. EXTRUSION TWIST 1.0DEG PER 1M [1.0DEG/FOOT]
3. EXTRUSION CROSS SECTIONAL AREA IS 100.53mm sq. [0.1558 sq. in.]
4. SECTIONAL MATERIAL THICKNESS 1.50mm±0.15mm [0.059"±0.006"] UNLESS OTHERWISE SPECIFIED
5. ALL RADII & FILLET RADIUS TO BE R0.40mm [0.016"] UNLESS OTHERWISE SPECIFIED
6. REFERENCE DIMENSIONS ARE SHOWN WITHIN ()
7. CRITICAL DIMENSIONS ARE SHOWN WITHIN
8. ALL DIMENSIONS ARE FINISHED PART DIMENSIONS
9. ALL DIMENSIONS AND TOLERANCES ARE TO BE INTERPRETED ACCORDING TO ASME Y14.
10. SURFACE FINISH AS PER CUSTOMER'S PURCHASE ORDER

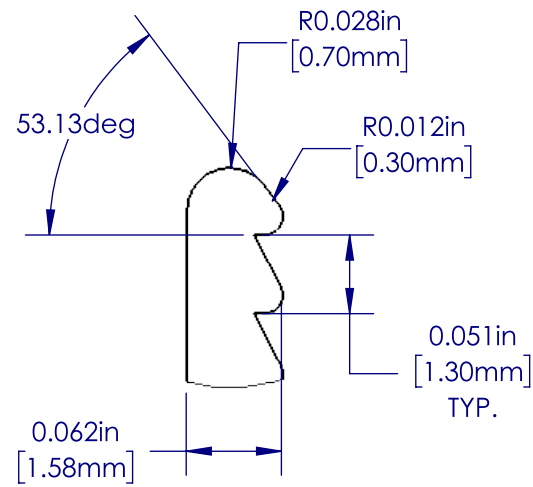
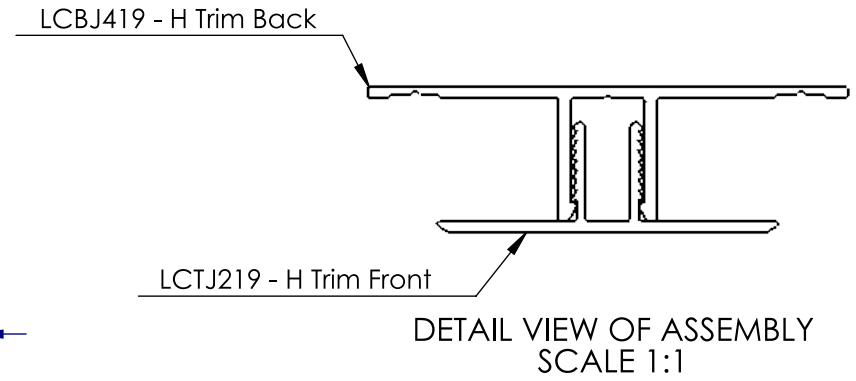

DETAIL A
SCALE 8:1

--- EXPOSED SURFACE

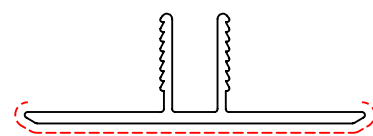

EXTRUSION PROFILE
SCALE 1:1

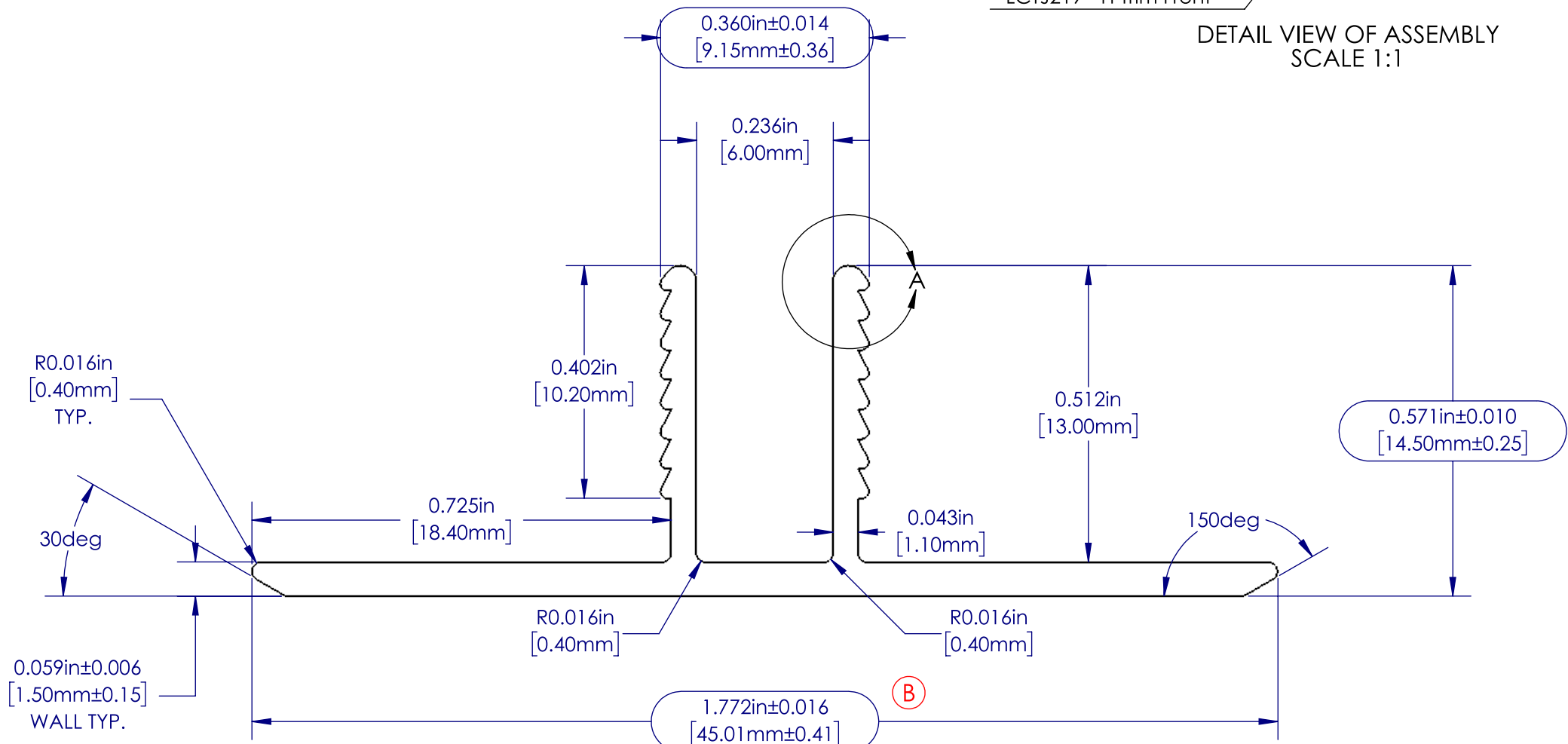

WEIGHT/LENGTH	0.274	kg/m	0.184	lbs./ft.
AREA	100.53	sq. mm	0.1558	sq. in.
TOTAL PERIMETER	149.26	mm	5.8763	in.
OUTSIDE PERIMETER	149.26	mm	5.8763	in.
EXPOSED PERIMETER	47.10	mm	1.8542	in.

B

PROPRIETARY AND CONFIDENTIAL
THE INFORMATION CONTAINED IN THIS DRAWING IS THE SOLE PROPERTY OF ALWOOD LLC. ANY REPRODUCTION IN PART OR AS A WHOLE WITHOUT THE WRITTEN PERMISSION OF ALWOOD LLC IS PROHIBITED.

UNLESS OTHERWISE SPECIFIED: DIMENSIONS ARE IN INCHES [MM] TOLERANCES:		NAME	DATE	
MILLIMETERS	INCHES	EASS	6/25/20	
X = ±1	[.X = ±0.1]			TITLE:
.X = ±.20	[.XX = ±0.01]			H Trim Front
.XX = ±10	[.XXX = ±0.005]			SIZE
ANGLES	∠ = ± 1°			B
FRACTIONS	X/X = ± 1/64			PART NO.
INTERPRET GEOMETRIC TOLERANCING PER:				LCTJ219
MATERIAL	6063-T5			REV
FINISH	Powder Coat			B
NEXT ASSY	USED ON			SCALE: 4:1
APPLICATION				WEIGHT: 0.30
				SHEET 2 OF 2