



LEVANTÉ[®]
ALUMINUM ARCHITECTURAL COMPONENTS

LEVANTÉ[®], LLC
901 NORTHVIEW ROAD
SUITE 100
WAUKESHA, WISCONSIN 53188

Project Name:

Part Name:

ONE WAY FENCE POST

Used on assembly:

Part No.:

LF1POST410

Drawing Number:

HLM-AE-0013-000-B

REVISIONS

REV.	DESCRIPTION	DATE	APPROVED
B	SCREW BOSSES HAVE BEEN ADDED TO PROFILE AS PER CUSTOMER'S REVISION NOTES.	7/14/2020	EASS

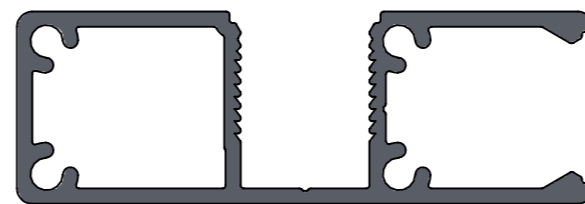

EXTRUSION PROFILE
SCALE 1:1

NOTES:

1. EXTRUSION SHALL BE STRAIGHT WITHIN 1.1mm PER 1M [0.015"/FOOT]
2. EXTRUSION TWIST 1.0DEG PER 1M [1.0DEG/FOOT]
3. EXTRUSION CROSS SECTIONAL AREA IS 0.6965 sq.in. [449.35mm sq.]
4. ALL RADII & FILLET RADIUS TO BE R0.016" [0.41mm] UNLESS OTHERWISE SPECIFIED
5. SECTIONAL MATERIAL THICKNESS 0.079"±0.006" [2.01mm±0.15mm] UNLESS OTHERWISE SPECIFIED
6. CRITICAL DIMENSIONS ARE SHOWN WITHIN ()
7. REFERENCE DIMENSIONS ARE SHOWN WITHIN ()
8. ALL DIMENSIONS ARE FINISHED PART DIMENSIONS
9. ALL DIMENSIONS AND TOLERANCES ARE TO BE INTERPRETED ACCORDING TO ASME Y14.
10. SURFACE FINISH AS PER CUSTOMER'S PURCHASE ORDER

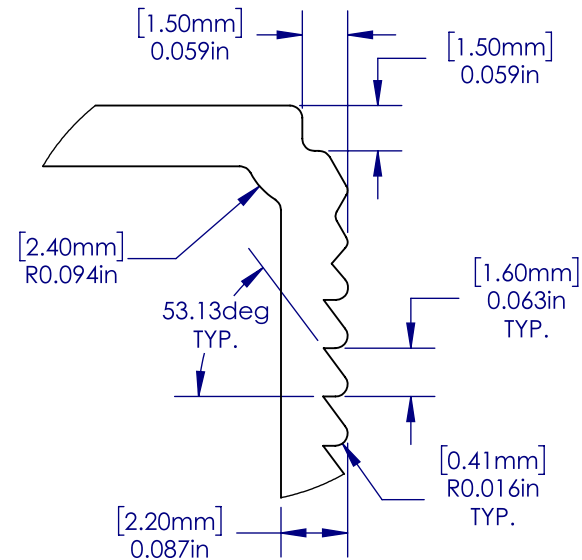

DETAIL A SCALE 4:1

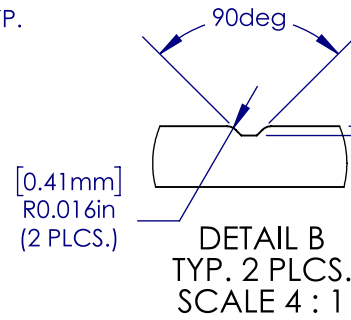

DETAIL B TYP. 2 PLCS. SCALE 4:1

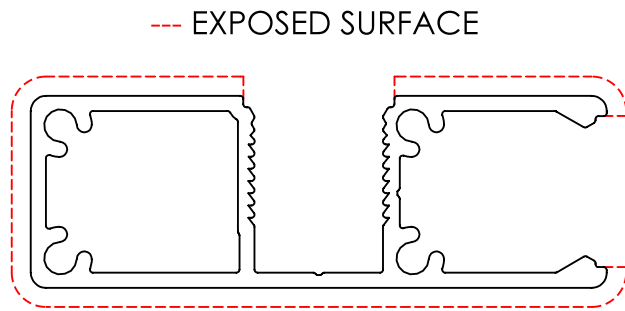

EXTRUSION PROFILE SCALE 1:1

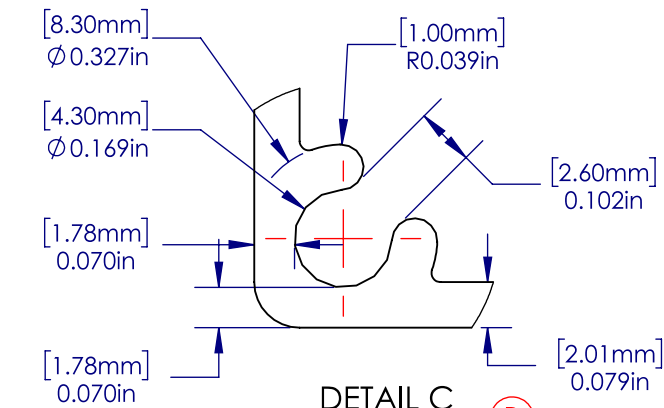

DETAIL C SCALE 3:1

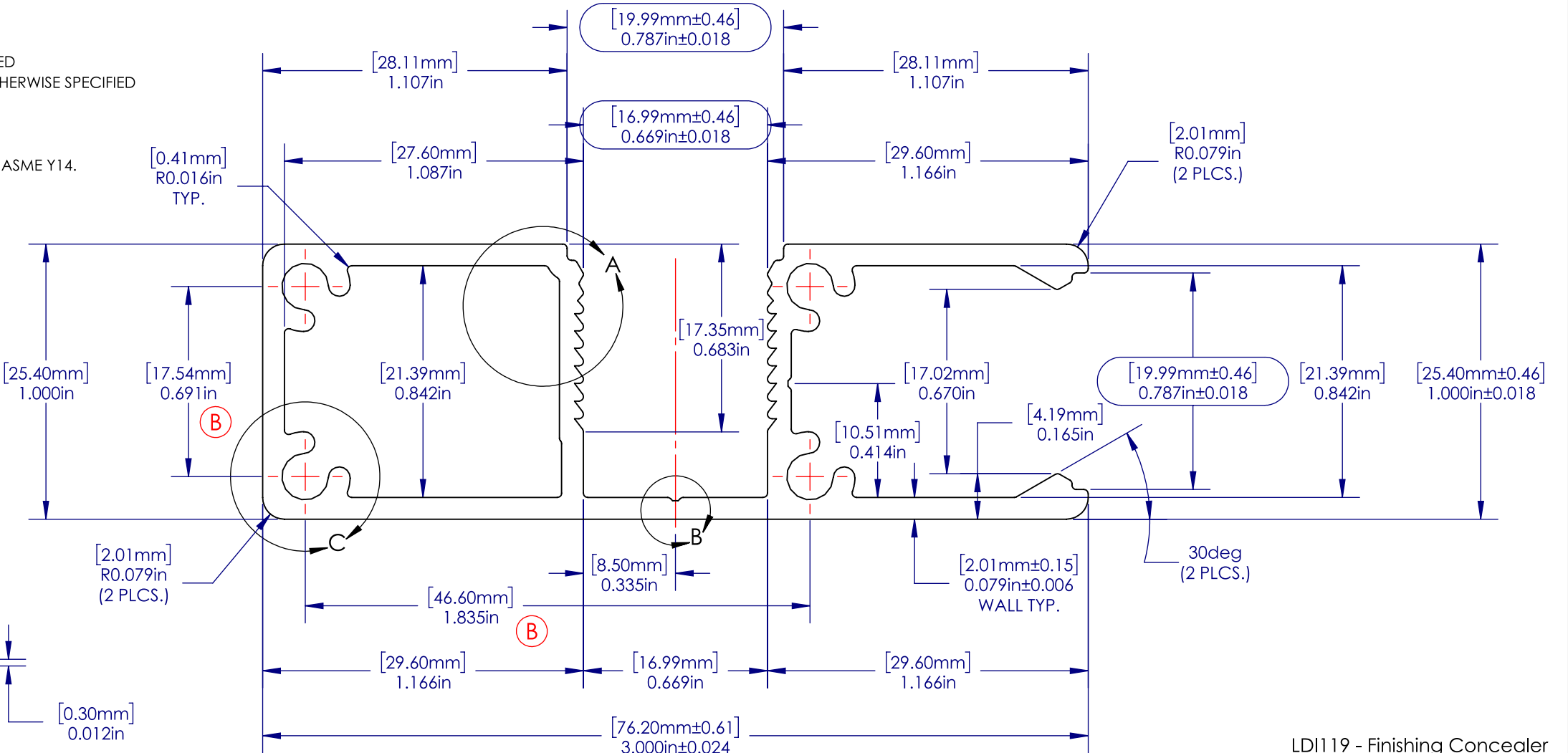

LF1POST410 - 1-Way Fence Post

DETAIL VIEW OF ASSEMBLY SCALE 1:1

LD1119 - Finishing Concealer

WEIGHT/LENGTH	1.227	kg/m	0.824	lbs./ft.
AREA	449.35	sq. mm	0.6965	sq. in.
TOTAL PERIMETER	441.42	mm	17.3789	in.
OUTSIDE PERIMETER	332.69	mm	13.0979	in.
EXPOSED PERIMETER	163.77	mm	6.4477	in.

PROPRIETARY AND CONFIDENTIAL
 THE INFORMATION CONTAINED IN THIS DRAWING IS THE SOLE PROPERTY OF ALWOOD LLC. ANY REPRODUCTION IN PART OR AS A WHOLE WITHOUT THE WRITTEN PERMISSION OF ALWOOD LLC IS PROHIBITED.

UNLESS OTHERWISE SPECIFIED: DIMENSIONS ARE IN INCHES [MM] TOLERANCES:		NAME	DATE
MILLIMETERS	INCHES	EASS	07/14/20
X = ±1	[.X = ±0.1]	DRAWN	
.X = ±.25	[.XX = ±0.01]	CHECKED	
.XX = ±10	[.XXX = ±0.005]	ENG APPR.	
ANGLES	∠ = ± 1°	MFG APPR.	
FRACTIONS	X/X = ± 1/64	Q.A.	
INTERPRET GEOMETRIC TOLERANCING PER:		COMMENTS:	
MATERIAL	6063-T5		
FINISH	Powder Coat		
NEXT ASSY	USED ON		
APPLICATION	DO NOT SCALE DRAWING		



TITLE:
One Way Fence Post

SIZE	PART NO.	REV
B	LF1POST410	B
SCALE: 2:1	WEIGHT: 3.610	SHEET 2 OF 2