



LEVANTÉ[®]
ALUMINUM ARCHITECTURAL COMPONENTS

LEVANTÉ[®], LLC
901 NORTHVIEW ROAD
SUITE 100
WAUKESHA, WISCONSIN 53188

Project Name:

Part Name:

150mm STANDARD BOARD

Used on assembly:

Part No.:

LS619

Drawing Number:

AL-13622-A

REVISIONS

REV.

DESCRIPTION

DATE

APPROVED



EXTRUSION PROFILE
SCALE 1:1

4

3

2

1

NOTES:

- 1. EXTRUSION SHALL BE STRAIGHT WITHIN 1.1mm PER 1M [0.015"/FOOT]
- 2. EXTRUSION TWIST 1.0DEG PER 1M [1.0DEG/FOOT]
- 3. EXTRUSION CROSS SECTIONAL AREA IS 0.8111 sq.in. [523.27mm sq.]
- 4. ALL RADII & FILLET RADIUS TO BE R0.031" [0.79mm] UNLESS OTHERWISE SPECIFIED
- 5. SECTIONAL MATERIAL THICKNESS 0.059"±0.006" [1.50mm±0.15mm] UNLESS OTHERWISE SPECIFIED
- 6. CRITICAL DIMENSIONS ARE SHOWN WITHIN ()
- 7. REFERENCE DIMENSIONS ARE SHOWN WITHIN ()
- 8. ALL DIMENSIONS ARE FINISHED PART DIMENSIONS
- 9. ALL DIMENSIONS AND TOLERANCES ARE TO BE INTERPRETED ACCORDING TO ASME Y14.

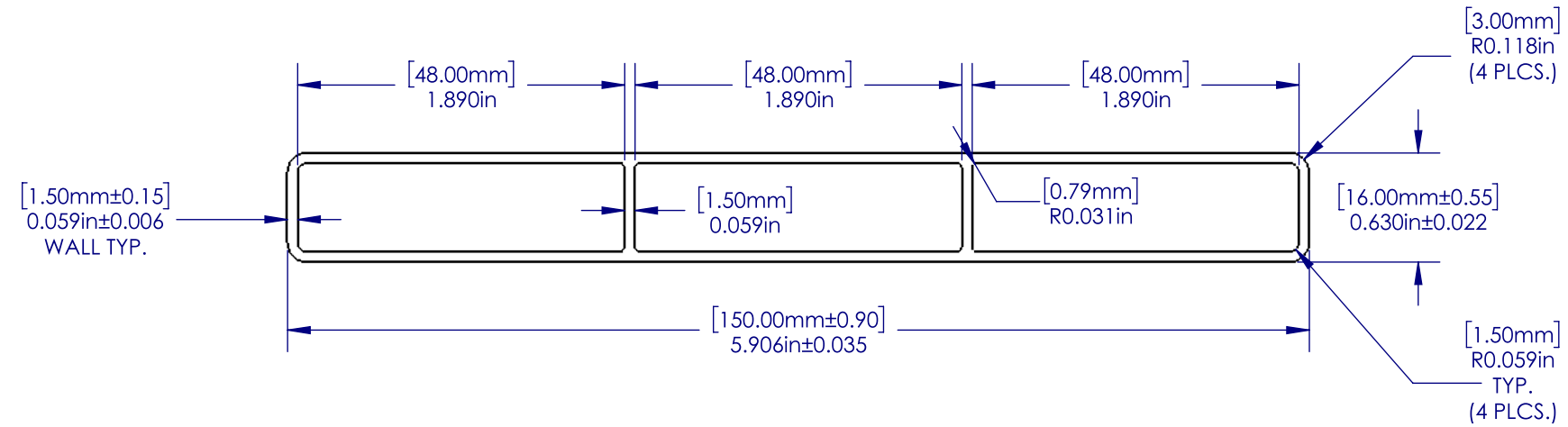

--- EXPOSED SURFACE

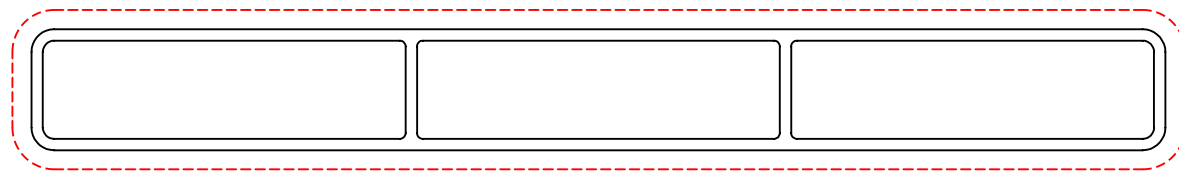

EXTRUSION PROFILE
SCALE 1:1

WEIGHT/LENGTH	1.429	kg/m	0.960	lbs./ft.
AREA	523.27	sq. mm	0.8111	sq. in.
TOTAL PERIMETER	687.57	mm	27.0698	in.
OUTSIDE PERIMETER	326.85	mm	12.8681	in.
EXPOSED PERIMETER	326.85	mm	12.8681	in.

PROPRIETARY AND CONFIDENTIAL
THE INFORMATION CONTAINED IN THIS
DRAWING IS THE SOLE PROPERTY OF
ALWOOD LLC. ANY REPRODUCTION
IN PART OR AS A WHOLE
WITHOUT THE WRITTEN PERMISSION OF
ALWOOD LLC IS PROHIBITED.

		UNLESS OTHERWISE SPECIFIED: DIMENSIONS ARE IN INCHES [MM] TOLERANCES:		NAME	DATE	 LEVANTÉ ALUMINUM ARCHITECTURAL COMPONENTS
		MILLIMETERS	INCHES	EASS	05/26/20	
		X = ±1	[.X = ± 0.1]	DRAWN		TITLE:
		.X = ± .25	[.XX = ± 0.01]	CHECKED		150mm Standard Board
		.XX = ± 10	[.XXX = ± 0.005]	ENG APPR.		SIZE PART NO.
		ANGLES	∠ = ± 1°	MFG APPR.		B LS619
		FRACTIONS	X/X = ± 1/64	Q.A.		REV
		INTERPRET GEOMETRIC TOLERANCING PER:		COMMENTS:		A
		MATERIAL	6063-T5			SCALE: 1:1 WEIGHT: 0.949 SHEET 2 OF 2
NEXT ASSY	USED ON	FINISH	Powder Coat			
APPLICATION		DO NOT SCALE DRAWING				

4

3

2

1