



LEVANTÉ[®]
ALUMINUM ARCHITECTURAL COMPONENTS

LEVANTÉ[®], LLC
901 NORTHVIEW ROAD
SUITE 100
WAUKESHA, WISCONSIN 53188

Project Name:
H.L.M.

Part Name:
50MM STANDARD BOARD

Used on assembly:

Part No.:
LS219

Drawing Number:
HLM-AE-000347-MU-A

REVISIONS

REV.	DESCRIPTION		
A	Initial Release		



EXTRUSION PROFILE
SCALE 1:1

4

3

2

1

NOTES:

1. REFER TO CAD MODEL FOR UNSPECIFIED DIMENSIONS
2. EXTRUSION SHALL BE STRAIGHT WITHIN 1.1mm PER 1M [0.015"/FOOT]
3. EXTRUSION TWIST 1.0DEG PER 1M [1.0DEG/FOOT]
4. EXTRUSION CROSS SECTIONAL AREA IS 148.91 mm sq. [0.231 sq.in.]
5. ALL RADII & FILLET RADIUS TO BE 3.00 mm [0.118 in.] UNLESS OTHERWISE SPECIFIED
6. SECTIONAL MATERIAL THICKNESS 1.19 mm [0.047in.] UNLESS OTHERWISE SPECIFIED
7. CRITICAL DIMENSIONS ARE SHOWN WITHIN ()
8. REFERENCE DIMENSIONS ARE SHOWN WITHIN ()
9. ALL DIMENSIONS INTERPRETED ACCORDING TO ASME Y14
10. ALL TOLERANCES ARE BASED ON ANSI H35.2
11. LOCATE EXTRUDER ID MARKS IN REGION INDICATED
12. EXTRUDER ID MARKS ARE DEFINED IN DETAIL "ID MARKS"

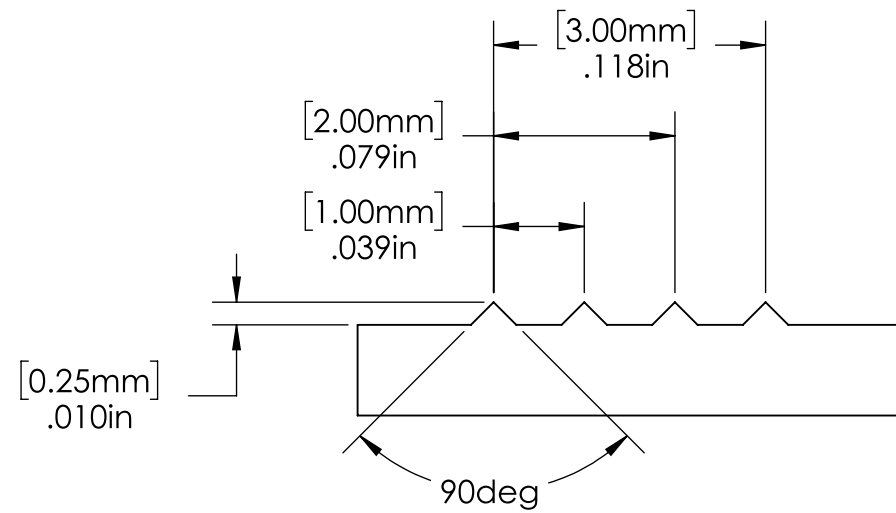

DETAIL ID MARKS
SCALE 12:1



--- EXPOSED SURFACES
SCALE 1:1

WEIGHT/LENGTH	0.402	kg/m	0.270	lbs./ft.
AREA	148.91	sq. mm	0.231	sq. in.
TOTAL PERIMETER	249.57	mm	9.826	in.
OUTSIDE PERIMETER	128.46	mm	5.057	in.
EXPOSED PERIMETER	128.46	mm	5.057	in.

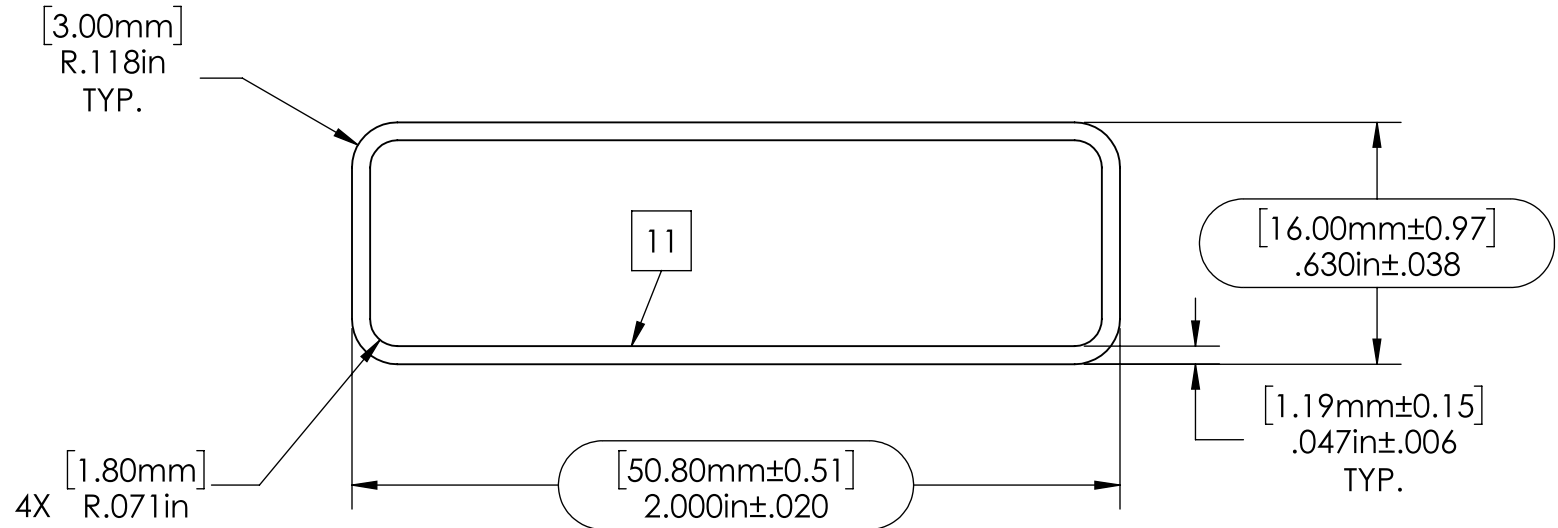

EXTRUSION PROFILE
SCALE 2:1

PROPRIETARY AND CONFIDENTIAL
THE INFORMATION CONTAINED IN THIS DRAWING IS THE SOLE PROPERTY OF ALWOOD LLC. ANY REPRODUCTION IN PART OR AS A WHOLE WITHOUT THE WRITTEN PERMISSION OF ALWOOD LLC IS PROHIBITED.

		UNLESS OTHERWISE SPECIFIED: DIMENSIONS ARE IN INCHES [MM] TOLERANCES:		NAME	DATE	
		MILLIMETERS	INCHES	DRAWN	GVP	
		X = ±1	[.X = ± 0.1]	CHECKED		
		.X = ± .20	[.XX = ± 0.01]	ENG APPR.		
		.XX = ± 10	[.XXX = ± 0.005]	MFG APPR.		
		ANGLES	∠ = ± 1°	Q.A.		
		FRACTIONS	X/X = ± 1/64	COMMENTS:		
		INTERPRET GEOMETRIC TOLERANCING PER:				
		MATERIAL	6063-T5			
		FINISH	Powder Coat			
NEXT ASSY	USED ON	APPLICATION		DO NOT SCALE DRAWING		
				TITLE:		
				50mm Standard Board		
SIZE	PART NO.	REV				
B	LS219	A				
SCALE: 2:1	WEIGHT: N/A	SHEET 2 OF 2				

4

3

2

1