

Unique Aluminum Exterior Architectural Components with an Exotic Wood-Grain Look Designed for Commercial & Residential Use



LEVANTÉ[®]
ARCHITECTURAL ALUMINUM

DESIGN WITH
PRIDE.

DESIGN WITH
LEVANTÉ[®].

Give a contemporary look to any commercial or residential outside structure by adding extra dimension that a true wood grain look does. Levanté[®] elevates exterior façades by bringing life and style to elements that can become boring and outdated over time. Whether using it as an accent, on an angle, or as a rainscreen, the possibilities are endless.

PROTECTION POWERED BY DECORAL[®]

Finished with Decoral[®] powder coating, Levanté[®] wood grains are built with impeccable detail and resists fading and scratching.

MOONLIGHT
KISS



TWILIGHT
SUN



TOASTED
MARSHMALLOW



**Actual material color may vary from printed swatch samples.*



800.224.2995 | www.levantealuminum.com | response@levantealuminum.com



LEVANTÉ
ARCHITECTURAL ALUMINUM

**BEAUTIFUL.
DURABLE.
CREATED TO LAST.**



INSTALL FRIENDLY

Lightweight, easy to use component system that's workable with basic hand tools. Saves time and labor and requires no special fasteners.



ALL-SEASON PERFORMANCE

Non-porous surface where moisture absorption is non-existent. Levanté® endures throughout the seasons easily handling extreme times of heat or cold.



LOW-MAINTENANCE

Levanté® creates a carefree and cost effective outdoor environment that's easy to clean and lasts a lifetime.



FIRE RETARDANT

ASTM E84

Levanté® is fire retardant and non-combustible.



ECO-FRIENDLY

Aluminum is one of the most sustainable materials in the world. It's infinitely 100% recyclable.

LEVANTÉ® ALUMINUM CLADDING & SOFFITS COMPONENT SYSTEM

The Levanté® Aluminum Component System makes it easy to create your one of a kind space. Boards available in 19' lengths with 18'-11" of usable material.

STARTER TRIM



INTERLOCKING BOARD

Available in 4" & 6" widths



OUTSIDE CORNER TRIM

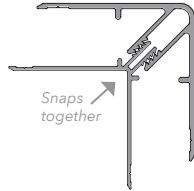

H-TRIM FRONT

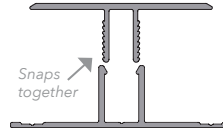

PERIMETER/DOOR & WINDOW TRIM FRONT



H-TRIM BACK

INSIDE CORNER TRIM

PERIMETER/DOOR & WINDOW TRIM BACK

MULTI-PURPOSE TORX SCREWS

#8 x 1-3/4" & 5/16" x 4"



WALL DETAIL

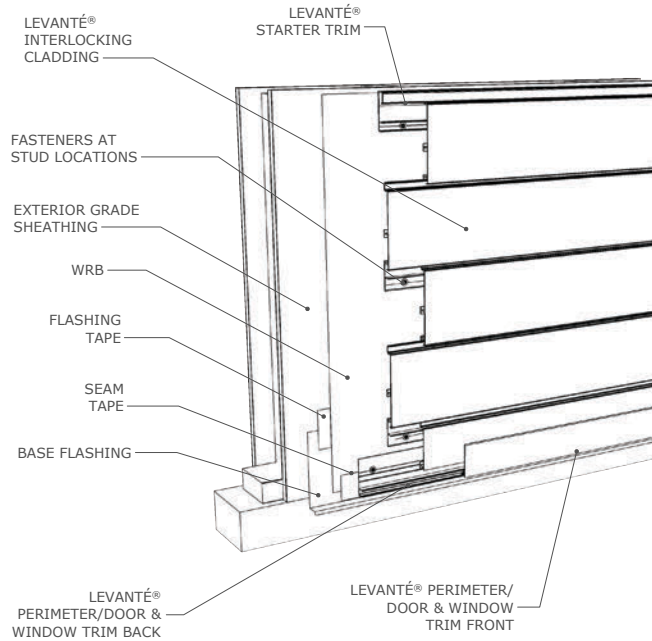

VERIFIED TESTING

Levanté® Aluminum Components have undergone various performance tests provided by a certified third-party testing agency.



FIRE TESTED
ASTM E84



WIND LOAD TESTED
ASTM D5206



MODIFIED IMPACT
RESISTANCE REPORT

View the complete Levanté® Architectural Aluminum System, visit www.levantealuminum.com

800.224.2995 | www.levantealuminum.com | response@levantealuminum.com

LVNTSELLSHEET-CLAD-SOF LCA24-0007 ©2024 Hallmark Building Supplies, Inc. is a Marketer & Distributor of Levanté® Architectural Aluminum



HALLMARK
building supplies inc.

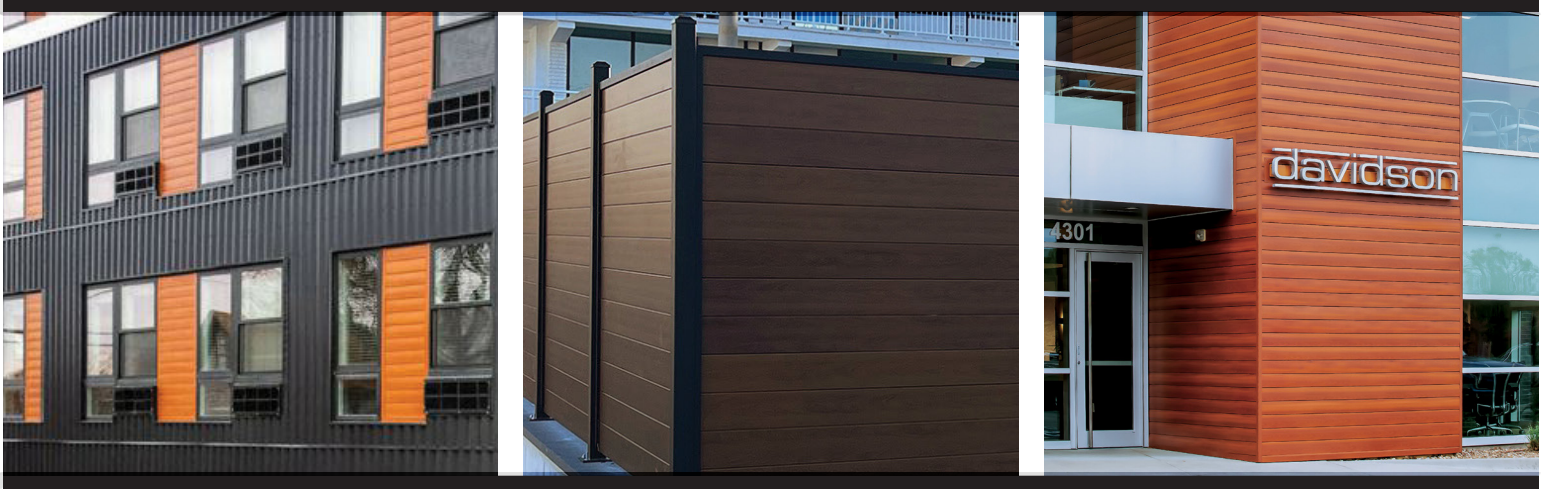

LEVANTÉ
ARCHITECTURAL ALUMINUM

Levanté® AIA Course

ALUMINUM EXTERIOR COMPONENTS WITH WOOD-GRAIN LOOK DESIGNED FOR HIGH PERFORMANCE

COURSE NUMBER: LEV2022C1
LEARNING UNITS: 1 LU | HSW



Course Description:

Using wood accents on commercial & residential exterior facades is a growing trend. Wood accents have also maintained their popularity in the interiors of homes & commercial spaces. Using real wood has maintenance challenges. Aluminum components made with a wood-grain look provide flexibility in architectural design & low-maintenance for the end-user.

Learning Objectives

- Identify architectural component materials and discuss material selection considerations
- Describe aluminum architectural elements in terms of their manufacture, components, and function
- Discuss the use of aluminum architectural elements and evaluate their performance benefits
- Explain how to properly install and maintain aluminum architectural components

hllmark.com | 800.642.2246 | response@hllmark.com



07 46 16

Aluminum Siding

Levanté® Premier Aluminum Cladding

PART 1- GENERAL:

1.1 SECTION INCLUDES

- A. Exterior, aluminum cladding system and accessories
- B. Interior, aluminum cladding system and accessories

1.2 RELATED SECTIONS

- A. Section 01 74 21- Construction/Demolition Waste Management and Disposal
- B. Section 05 41 00- Structural Metal Stud Framing
- C. Section 06 10 00- Rough Carpentry
- D. Section 06 16 00- Sheathing
- E. Section 07 20 00- Thermal Protection
- F. Section 07 25 00- Weather Barriers
- G. Section 07 60 00- Flashing and Sheet Metal

1.3 REFERENCES

- A. American Society for Testing and Materials (ASTM)
 - 1. ASTM E84- Standard Test Method for Surface Burning Characteristics of Building Materials
 - 2. ASTM E330/E330M – Standard Test Method for Structural Performance of Exterior Windows, Doors, Skylights and Curtain Walls by Uniform Static Air Pressure Difference
 - 3. ASTM D2244 – Standard Practice for Calculation of Color Tolerances and Color Differences
 - 4. ASTM F2957 Section 5 – Standard Specifications for Ornamental Aluminum Fence Systems - Structural Testing
 - 5. ASTM D4214 – Standard Test Methods for Evaluating the Degree of Chalking of Exterior Paint Films
 - 6. ASTM D5206-13- Standard Test Method for Wind Load Resistance
- B. American Architectural Manufacturers Association (AAMA)
 - 1. AAMA 615 – Voluntary Specification, Performance Requirements and Test Procedures for Superior Performing Organic Coatings on Plastic Profiles
 - 2. AAMA 2604-10 Voluntary Specification, Performance Requirements and Test Procedures for High Performance Organic Coatings on Aluminum Extrusions and Panels.
- C. American National Standards Institute (ANSI)
 - 1. Modified FM 4473 – Test Standard of Impact Resistance of Testing of Rigid Roofing Materials by impacting with Freezer Ice Balls.

1.4 SUBMITTALS

- A. Submit under provisions of Section 01 33 00.
- B. Product Data: Submit manufacturer's printed product literature, specifications, and data sheet.
- C. Product Samples: Submit manufacturer's 6" product samples of siding material in color and profile specified.

1. Interlocking board, standard board, self-mating board
2. Toasted Marshmallow, Twilight Sun, Moonlight Kiss
- D. Wall Sections & Details to indicate dimensions, profiles, attachment methods, schedule of wall elevations, trim and exposure pieces, soffits, fascia, metal furring, and related work.
- E. Certifications: Manufacturer's Certifications that products comply with specified requirements, including laboratory reports showing compliance with specified tests and standards.
- F. Submit manufacturer's installation instructions.
- G. Manufacturer's Warranty: Submit manufacturer's warranty.

1.5 QUALITY ASSURANCE

- A. Manufacturer Qualifications:
 1. Products covered under this section are to be manufactured in an ISO 9001 certified facility.
 2. Provide technical and design support as needed regarding installation requirements and warranty compliance provisions.
- B. Installer Qualifications:
 1. All products listed in this section are to be installed by a single installer trained by manufacturer or representative.
- C. Mock-Up Wall:
 1. Provide a mock up wall as evaluation tool for product and installation workmanship.
- D. Pre-Installation Meetings:
 1. Prior to beginning installation, conduct conference to verify and discuss substrate conditions, manufacturer's installation instructions and warranty requirements, and project requirements.

1.6 DELIVERY, STORAGE, AND HANDLING

- A. Deliver products in Manufacturer's packaging.
- B. Do not stack pallets more than two high.
- C. Pieces should be stored flat and in original packaging until use.
- D. Mark packaging, legibly. Indicate manufacturer's name, type, and color.
- E. Before installation, inspect products for damaged or defectives.
- F. Scrap material should be recycled.

1.7 WARRANTY

- A. Levanté®, LLC expressly warrants its products are free from manufacturing defects in material and workmanship if installed in accordance with our specifications, properly maintained, and used for their intended purpose for a period of 15 years.
- B. Decoral® expressly warrants for 15 years the color change will be less than five CIE Lab AE units calculated in accordance with AAMA 2604. The surface will exhibit a gloss retention of at least 30% of the original.
- C. Warranty is given to either (1) the original purchaser of the products; or (2) the owner of the property at the time of installation of the product.
- D. See warranty at levantealuminum.com for detailed information on terms, conditions and limitations.

PART 2- PRODUCTS:

2.1 MANUFACTURERS

- A. Acceptable Manufacturer: Levanté®, LLC, 901 Northview Rd, Suite 100, Waukesha, WI. 53188 www.levantealuminum.com

- B. Acceptable Distributor: Hallmark Building Supplies, Inc., 901 Northview Rd, Suite 100, Waukesha, WI. 53188. Toll Free: 1.800.642.2246, Fax: 1.800.688.7842, www.hllmark.com

2.2 SYSTEM PERFORMANCE

- A. Minor deviations to details shown on drawings to accommodate manufacturer's standard products may be acceptable by Architect of Record (AOR) when deviations do not affect design concept and specified performance.

2.3 PRODUCTS

1. Basis of Design Product: Levanté® Interlocking Boards
 - a. Profile Color: Toasted Marshmallow, Twilight Sun, Moonlight Kiss
 - b. Profile: Smooth woodgrain finish
 - c. Exposed Dimensions: 4" (96 mm) or 6" (150 mm)
 - d. Installed Panel Thickness: .63" (16 mm)
 - e. Finish: Semi-gloss
 - f. Weight:
 - i. 4" – .628 lbs. per ft
 - ii. 6" – .876 lbs. per ft
 - g. Approximate Coverage:
 - i. 4" – 6.33 sqft per board
 - ii. 6" – 9.5 sqft per board
2. Basis of Design Product: Levanté® Self-mating Boards
 - a. Profile Color: Toasted Marshmallow, Twilight Sun, Moonlight Kiss
 - b. Profile: Smooth woodgrain finish
 - c. Exposed Dimensions: 4" (100 mm) or 6" (150 mm)
 - d. Installed Panel Thickness: .63" (16 mm)
 - e. Finish: Semi-gloss
 - f. Weight:
 - i. 4" – .694 lbs. per ft (2 board thickness)
 - ii. 6" – 1.378 lbs. per ft (2 board thickness)
 - g. Approximate Coverage:
 - i. 4" - 6.33 sqft per board
 - ii. 6" – 9.5 sqft per board
3. Basis of Design Product: Levanté® Standard Boards
 - a. Profile Color: Toasted Marshmallow, Twilight Sun, Moonlight Kiss
 - b. Profile: Smooth woodgrain finish
 - c. Exposed Dimensions: 2" (50 mm), 4" (100 mm) or 6" (150 mm)
 - d. Installed Panel Thickness: .63" (16 mm)
 - e. Finish: Semi-gloss
 - f. Weight:
 - i. 2" – .270 lbs. per ft
 - ii. 4" – .601 lbs. per ft
 - iii. 6" – .953 lbs. per ft
 - g. Approximate Coverage:
 - i. 2" - 3.17 sqft per board
 - ii. 4" – 6.33 sqft per board
 - iii. 6" – 9.5 sqft per board
4. Accessory/Components:
 - a. Inside/Outside Corners (front and back)
 - b. Starter Track
 - c. Door and Window Trim (front and back)

- d. H Trim (front and back)
 - e. Finishing Trim
 - f. Finishing Concealer
 - g. Finishing Angle
 - h. For a full listing of all components visit www.levantealuminum.com
- 5. Substitutions: Not Permitted
 - 6. Requests for substitutions will be considered in accordance with the guidelines outlined in Section 01 60 00.

2.4 MATERIALS

- A. Aluminum components manufactured utilizing an extrusion die.
- B. Components are prefinished and machine applied.
- C. Material Variation: It is suggested to lay out several boards at a time to look for material variation. Avoid installing similar material consecutively. If similar grain pattern repetition cannot be avoided, staggering the pattern can be helpful.

2.5 INSTALLATION COMPONENTS

- A. All installation components are aluminum and have a factory finish matching the finish of the Interlocking, Self-Mating and Standard Boards
- B. Interlocking Boards – LDC419 and LDC619
 - 1. Starter Trim – LDS319
 - 2. Finishing Trim – LDCF219
 - 3. Finishing Concealer – LI119
 - 4. H Trim Front – LCTJ219
 - 5. H Trim Back – LCBJ419
 - 6. Door and Window Trim Front – LCTCL319
 - 7. Door and Window Trim Back – LCF319
 - 8. Inside Corner Trim – LCMC119
 - 9. Outside Corner Trim – LCFC119
- C. Self-Mating Boards
 - 1. Finishing Trim – LDCF219
 - 2. Finishing Concealer – LI119
 - 3. H Trim Front – LCTJ219
 - 4. H Trim Back – LCBJ419
 - 5. Door and Window Trim Front – LCTCL319
 - 6. Door and Window Trim Back – LCF319
 - 7. Inside Corner Trim – LCMC119
 - 8. Outside Corner Trim – LCFC119
- D. Standard Boards
 - 1. Finishing Trim – LDCF219
 - 2. Finishing Concealer – LI119
 - 3. H Trim Front – LCTJ219
 - 4. H Trim Back – LCBJ419
 - 5. Door and Window Trim Front – LCTCL319
 - 6. Door and Window Trim Back – LCF319
 - 7. Inside Corner Trim – LCMC119
 - 8. Outside Corner Trim – LCFC119
- E. Fasteners: Corrosion resistant fasteners, such as hot-dipped galvanized screws appropriate to local building codes and practices must be used. Use Hardened Aluminum fasteners in high humidity and high-moisture regions. Panel manufacturer is not liable for corrosion resistance of fasteners. Do not use fasteners that are not rated or designed for intended

- use. See manufacturer's instructions for appropriate fasteners for construction method used.
- F. Flashing: Flash all areas specified per manufacturer and design professional.
 - G. Sealant: Sealant to comply with ASTM C920, Class 50

PART 3: Execution

3.1 EXAMINATION

- A. Verification of Conditions
 - 1. Aluminum components can be installed over wood-based sheathing including 7/16" OSB and 1/2" plywood per published testing.
 - 2. Allowable Stud Spacing: 16" OC maximum
 - 3. A weather resistive barrier such as DuPont™ Tyvek® is required when installing aluminum components. Use an approved weather resistive barrier as defined by the 2015 IBC or IRC.
 - 4. Appropriate metal flashing should be used to prevent moisture penetration around all doors, windows, wall bottoms, material transitions and penetrations. Refer to local building codes for best practices.
 - 5. Examine site to ensure substrate conditions are within proper installation tolerances.
 - 6. Do not begin installation until proper conditions are present.
 - 7. Do not install components that are either damaged or defective.

3.2 INSTALLATION

- A. General: Install products in accordance with the latest installation guidelines of the manufacturer and all applicable building codes and other laws, rules, regulations and ordinances. Review all manufacturer installation, maintenance instructions, and other applicable documents before installation.
- B. Vertical Control/Expansion Joints are required at each vertical joint utilizing Levanté® Front and Back H Trim.
- C. Horizontal Compression Joints are required for multi-story installations of Levanté®. Locate joints at floor lines and per architectural drawings. Joints are flashed minimum 1" breaks. Do not caulk. Refer to installation guidelines.

3.3 CLEANING AND MAINTENANCE

- A. Refer to manufacturer's guidelines for detailed care instructions.



These guidelines presume the installer has a working knowledge of cladding/siding installation and the tools required. It is suggested to view installation video prior to starting installation.

INSTALLATION TOOLS CHECKLIST:

- Levanté[®] Aluminum boards and accessories
- Proper fasteners
- Miter saw with high tooth (*minimum 80*) count non-ferrous blade
- Circular saw with metal or aluminum blade
- Tape measure and standard construction level
- Safety equipment (*glasses, ear protection, etc.*)
- Rubber mallet

HAVE QUESTIONS?

Levanté[®] Quick Tech Support is available Monday-Friday. Our trained support team can consult on your project and provide installation techniques, verify material usage for application, and provide general guidance on working with Levanté[®]. Contact us at quicktech@levantealuminum.com for support.

PRODUCT DESCRIPTIONS & DIMENSIONS

BOARDS



Interlocking Boards: Available in 4" and 6" widths

100MM (4") INTERLOCKING BOARD

150MM (6") INTERLOCKING BOARD

STARTER TRIM



TRIM COMPONENTS

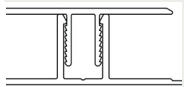

H-Trim: Front and Back

H-TRIM FRONT



H-TRIM BACK

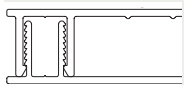

Door & Window Trim: Front and Back

DOOR & WINDOW TRIM FRONT



DOOR & WINDOW TRIM BACK



Can be used around openings and/or along finished edge of cladding/siding to conceal fasteners and create picture frame design.

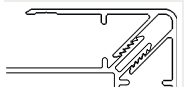

Inside Corner and Outside Corner

INSIDE CORNER



OUTSIDE CORNER



Finishing Angle



GETTING STARTED

FASTENERS:

Select an appropriate length #8 self-tapping corrosion-resistant exterior pan-head or truss-head screw. Fasteners must penetrate framing a minimum of 1". Choose a fastener material fit for use and climate.

CUTTING:

Miter saw use minimum 80 tooth non-ferrous metal-cutting blade. Circular saw can be used with aluminum or metal blades, 7-1/4" minimum 56 tooth count or 6-1/2" minimum 32 tooth count. Proper protection equipment should be used.

MATERIAL VARIATION:

It is suggested to lay out several boards at a time to look for material variation. Avoid installing similar material consecutively. If similar material cannot be avoided, staggering the pattern along the wall can be helpful.

FRAMING/ WALL CONSTRUCTION:

These guidelines do not supersede any local code regulations.

Framing should be a maximum of 16" on center. Levanté® sheds water but is not waterproof, a water barrier system such as DuPont™ Tyvek® should be properly installed as part of the wall system.

HORIZONTAL CLADDING INSTALLATION

- 1** Inspect all material once delivered prior to installation to ensure no damage or defects.
- 2** Review area where Levanté® is to be installed checking for proper framing and noting product layout and accessory use.
 - a. Fasteners should be installed through the sheathing and into the framing a minimum of 1".
- 3** When installing any Levanté® products pre-drill holes 1/8" larger than screw to allow for expansion and contraction of the material. Levanté® may expand or contract up to 3/16" in 19 ft boards with change in temperature. H-Trim can be used at butt joints to allow for movement.
 - a. For aesthetic purposes, exposed joints can be painted with exterior grade paint.

CONTINUED

- 4** Install Door and Window Trim Back piece around openings to framing. Fasten with approved fasteners.



- 5** Install Corner Trim Back to framing. Fasten with approved fasteners.

Make sure to stagger screws on either side of the corner so they do not conflict. It is recommended placing fastener $\frac{1}{4}$ " from the spine.

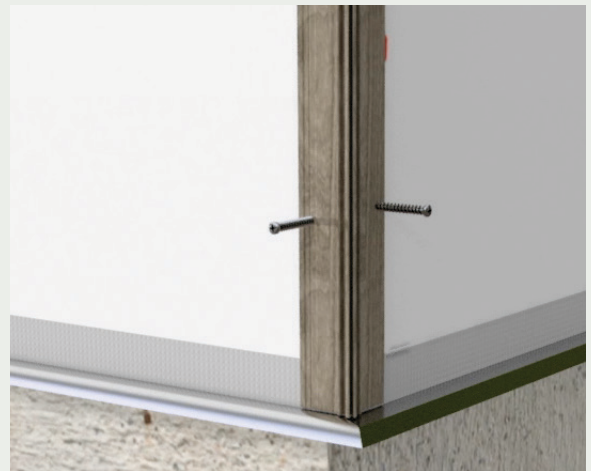

- 6** Install Door/Window Back Trim pieces at base of wall, when installing top down, and perimeter, as desired, to framing. It is recommended that Door/Window Trim butt to the Corner Back Trim. Fasten with approved fasteners.

- a. It is recommended to start at the top for better water management, however, material can be installed bottom to top at installers choice based on application. If installing bottom to top, Door and Window Back Trim would be installed at top of wall.



CONTINUED

7 Install required H-Trim Back to framing. Fasten with approved fasteners.

8 Install Starter Trim on structure and perpendicular to framing making sure to extend over previously installed trim piece flanges leaving $\frac{1}{2}$ " to $\frac{5}{8}$ " between starter edge and trim back spine. Fasten with approved fasteners.

- a. It is recommended to start at the top for better water management, however, material can be installed bottom to top at installers choice based on application.



9 Install Interlocking boards working away from Starter Trim.

- a. Make sure to cut boards $\frac{1}{2}$ " to $\frac{5}{8}$ " short on each end when using trim pieces to allow for expansion and contraction. Leave $\frac{1}{2}$ " to $\frac{5}{8}$ " on each end between board edge and trim spine.
- b. It is recommended that fasteners for trim backs do not conflict with Interlocking board legs.



CONTINUED

- 10** Install Door & Window Trim Front accessory pieces around openings by snapping the front sections into the back.



- 11** Install Corner Trim Front pieces by snapping the front sections into the back.



- 12** Install Door and Window Trim pieces around perimeter and base of wall by snapping the front section into the back.



- 13** Install H-Trim Front pieces by snapping the front sections into the back.

REGISTER YOUR LEVANTÉ® CLADDING:

Please register your Levanté® product within 45 days of installation.

www.levantealuminum.com/warranty/

VIEW THE LEVANTÉ® CLADDING INSTALLATION VIDEO:

<https://levantealuminum.com/product/architectural-aluminum-applications/>

QUESTIONS? Call your local Levanté® Installation Specialist at 800.642.2246.



DA22-0018 ©2022 Hallmark Building Supplies, Inc. is a Marketer & Distributor of Levanté® Aluminum Architectural Components.
Version 04.2022

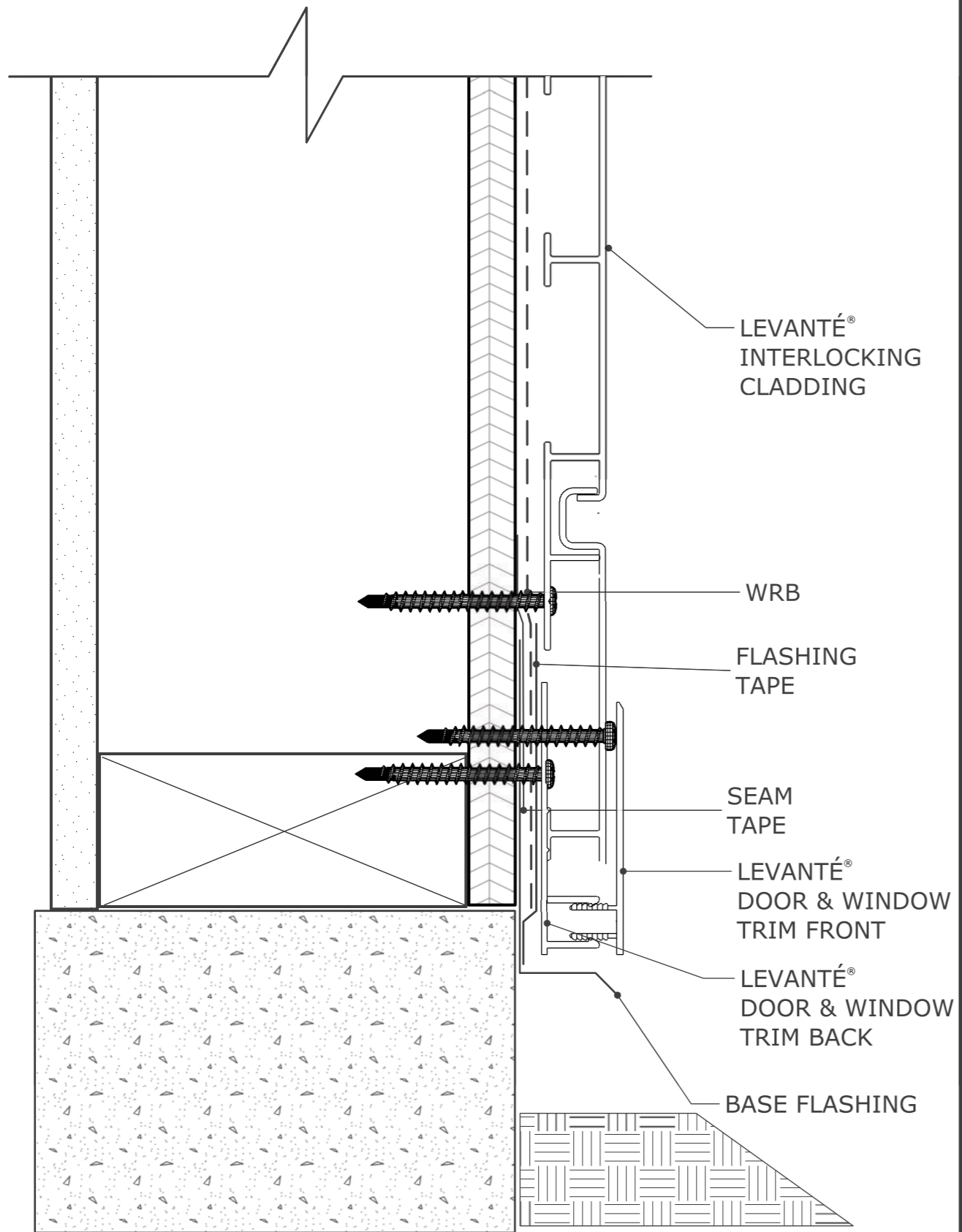

SECTION VIEW

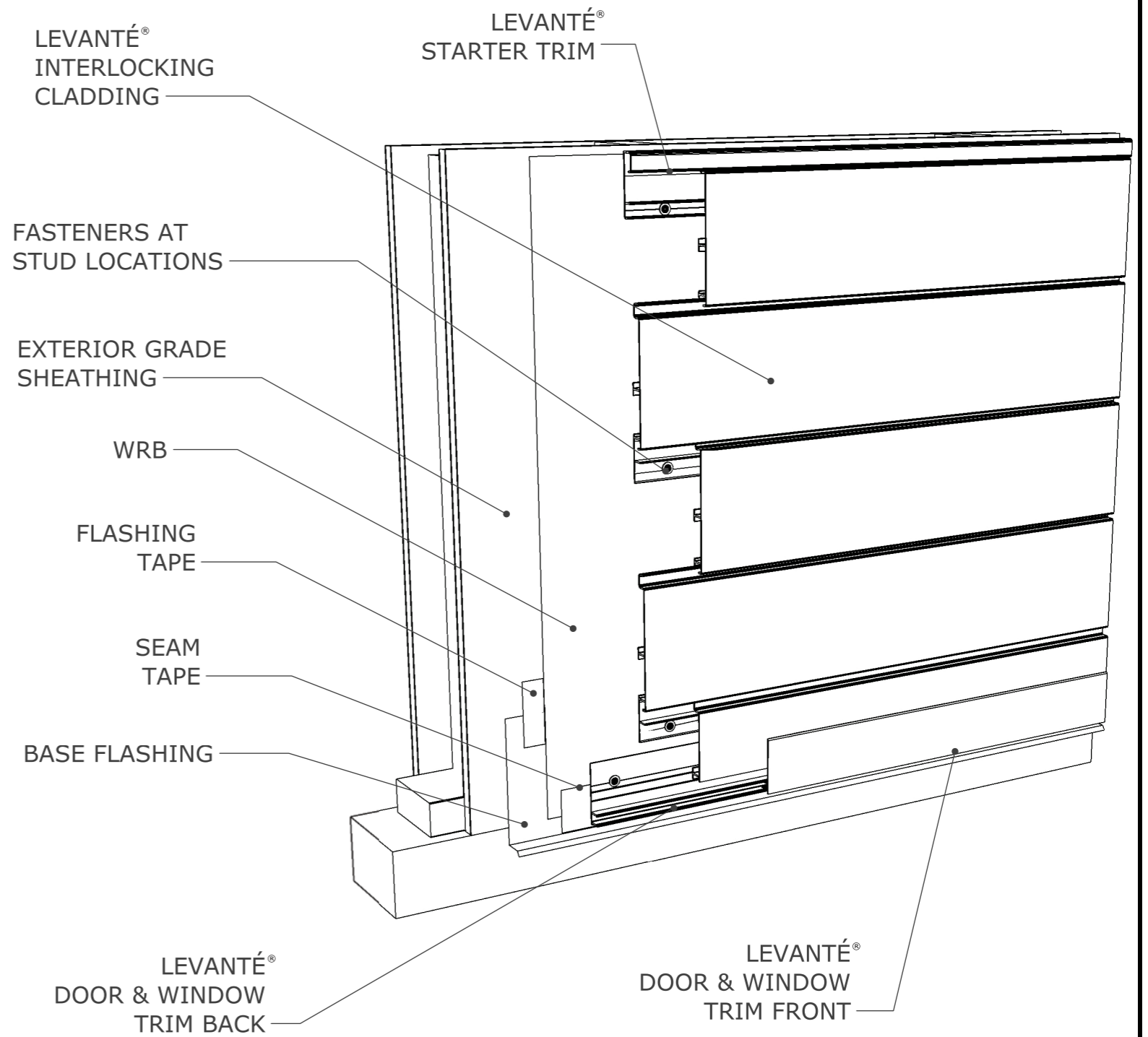

3D VIEW

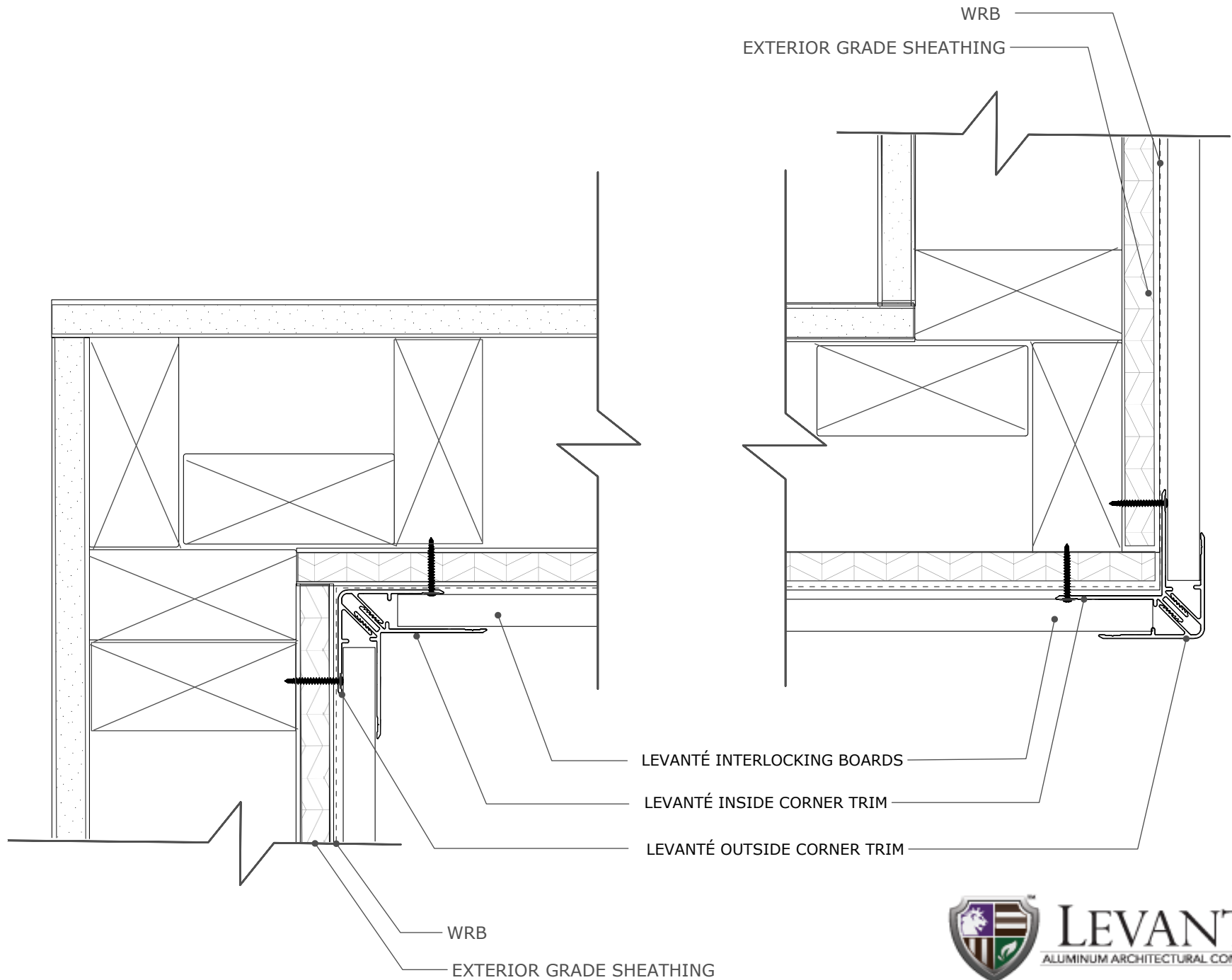

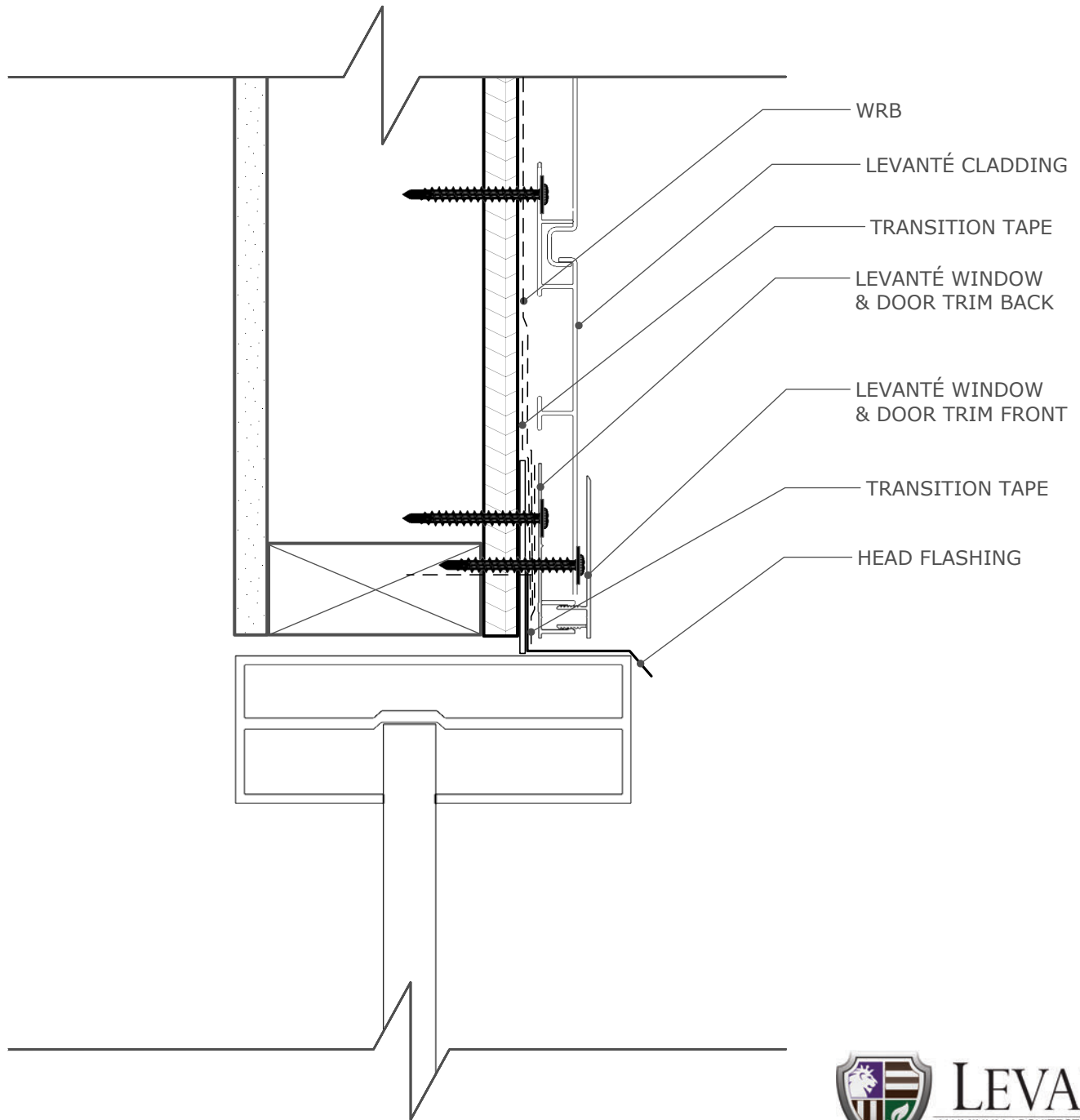

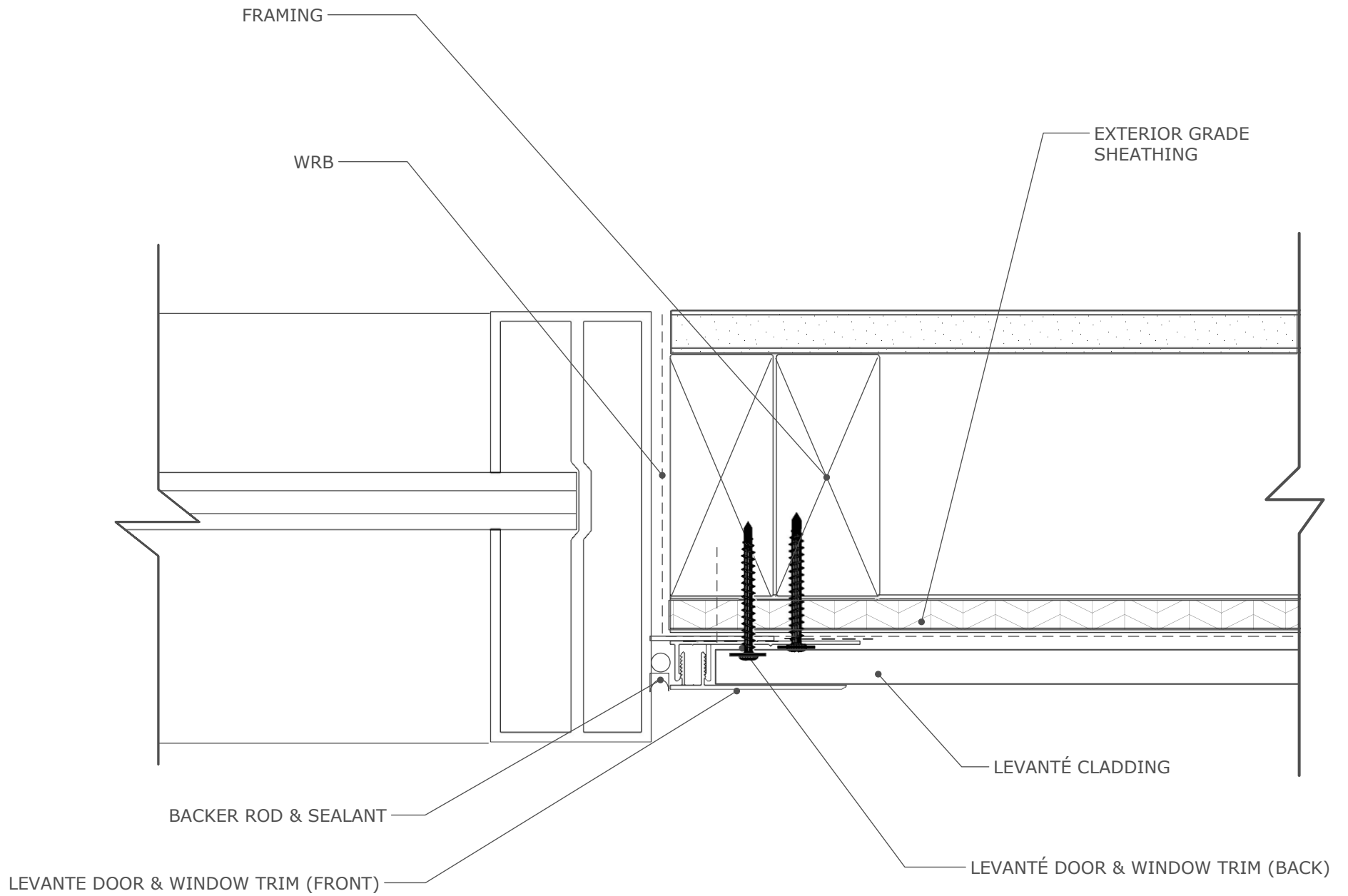

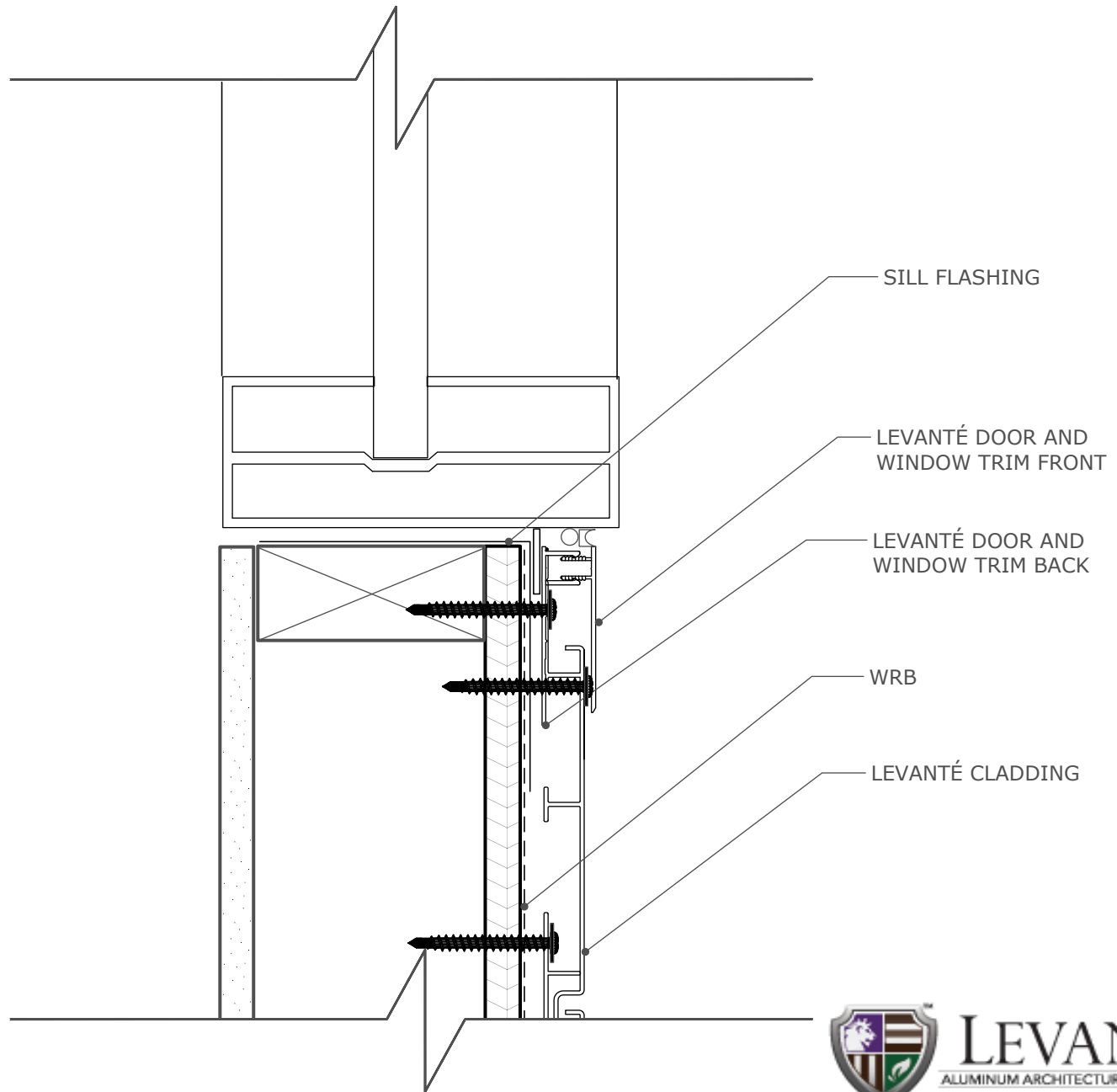

LEVANTÉ
 ALUMINUM ARCHITECTURAL COMPONENTS

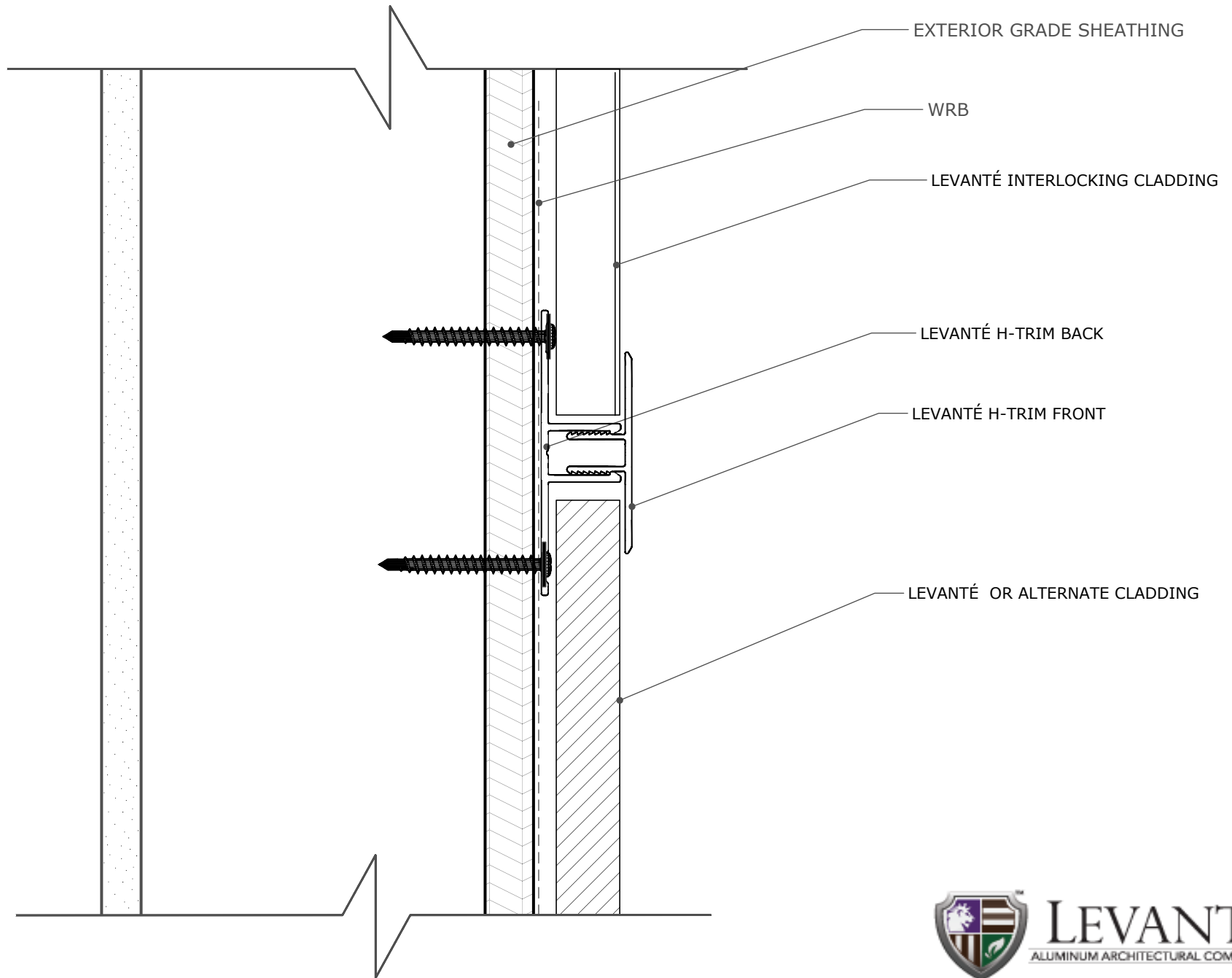

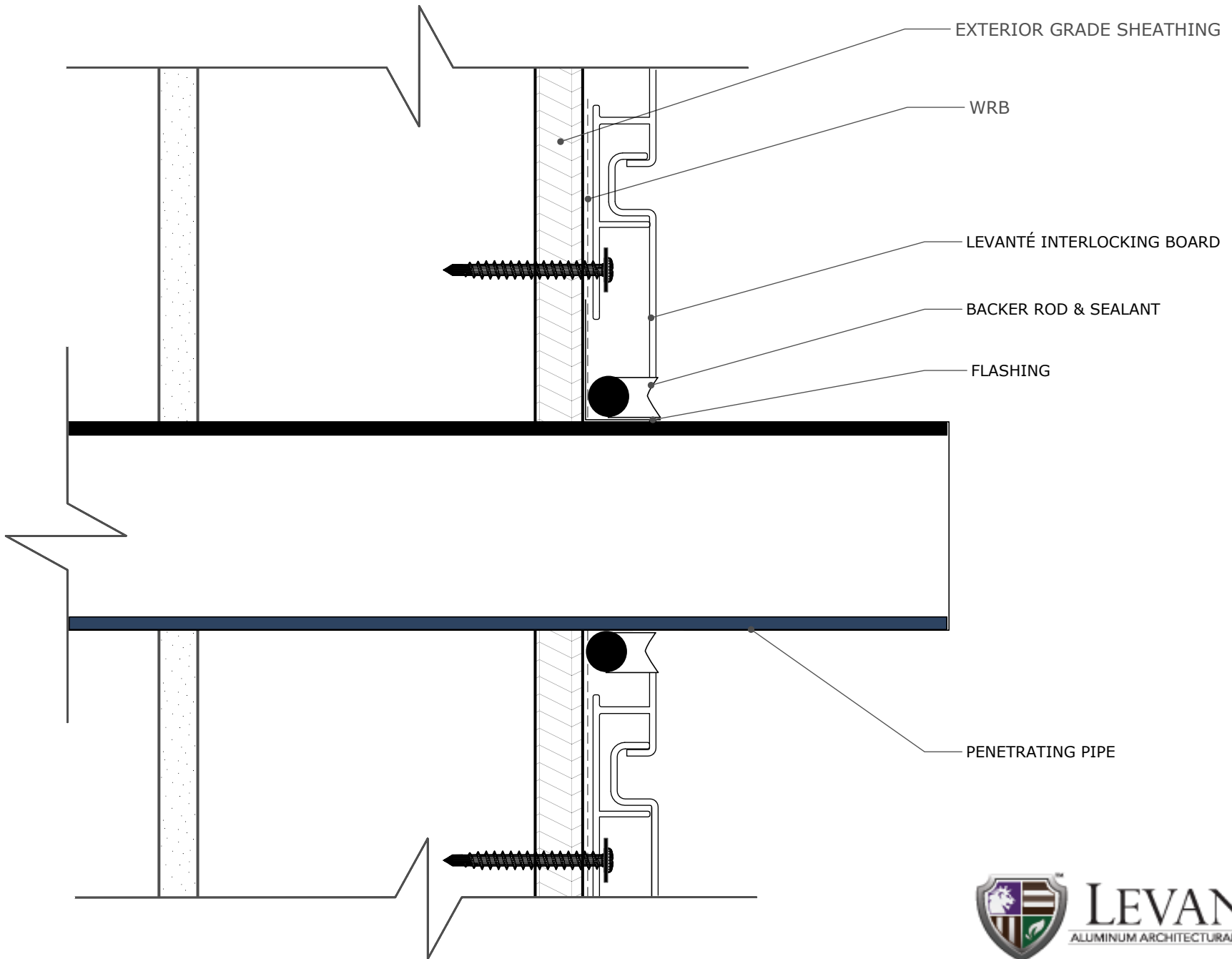

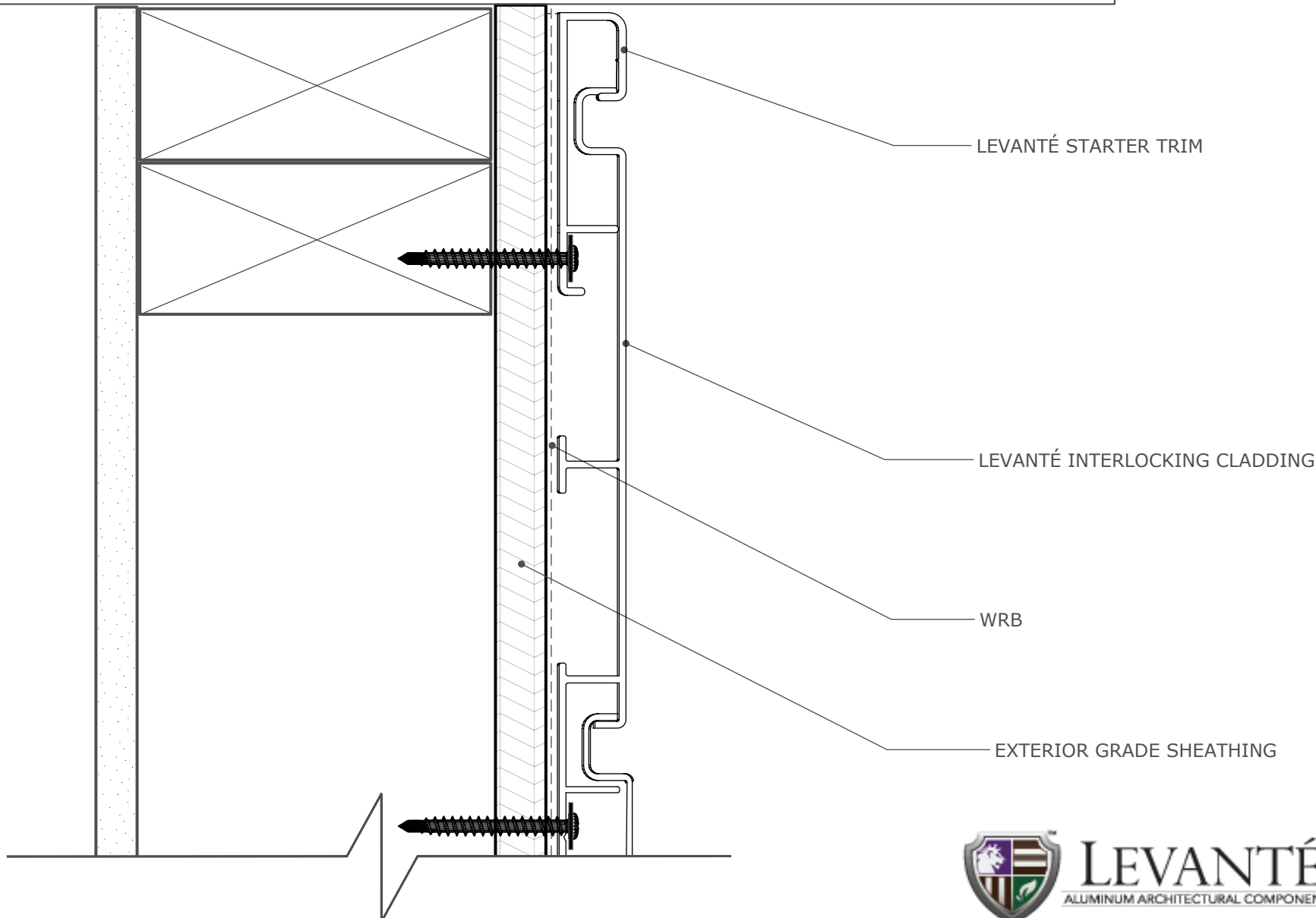

HALLMARK BUILDING SUPPLIES, INC. FIRE TEST REPORT

SCOPE OF WORK

ASTM E84 TESTING ON INTERLOCKING PANELS, MODEL LDC-419

REPORT NUMBER

103953780SAT-001A

TEST DATE

5/29/19

ISSUE DATE

5/30/19

PAGES

12

DOCUMENT CONTROL NUMBER

RT-R-AMER-Test-2780 (9/19/18)

© 2017 INTERTEK

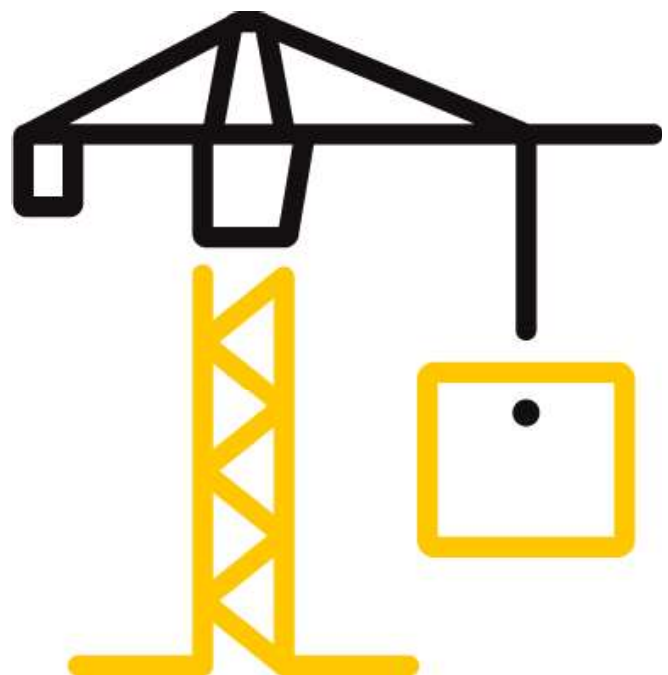

TEST REPORT FOR HALLMARK BUILDING SUPPLIES, INC.

Report No.: 103953780SAT-001A

Date: 5/30/19

REPORT ISSUED TO

Hallmark Building Supplies, Inc.

901 Northview Road
Waukesha, WI 53188

SECTION 1

SCOPE

Intertek Building & Construction (B&C) was contracted by Hallmark Building Supplies, Inc., 901 Northview Road, Waukesha, WI 53188, to evaluate the flame spread and smoke developed properties of Interlocking panels, Model LDC-419. Testing was conducted at the Intertek B&C test facility in Elmendorf, Texas. Results obtained are tested values and were secured by using the designated test method(s). A summary of test results and the complete graphical test data is reported herein.

This report does not constitute performance certification of this product nor an opinion or endorsement by this laboratory. Intertek B&C will service this report for the entire test record retention period. The test record retention period ends four years after the test date. Test records, such as detailed drawings, datasheets, representative samples of test specimens, or other pertinent project documentation, will be retained for the entire test record retention period.

SECTION 2

SUMMARY OF TEST RESULTS

Specimen I.D.: Interlocking panels, Model LDC-419

ASTM E84 Test Results

FLAME SPREAD INDEX	SMOKE DEVELOPED INDEX
0	5

*See Section 8 for additional information and commentary

For INTERTEK B&C:

COMPLETED BY:	Joseph Martinez	REVIEWED BY:	Servando Romo
TITLE:	Technician	TITLE:	Project Engineer
SIGNATURE:		SIGNATURE:	
DATE:	5/30/19	DATE:	5/31/19

This report is for the exclusive use of Intertek's Client and is provided pursuant to the agreement between Intertek and its Client. Intertek's responsibility and liability are limited to the terms and conditions of the agreement. Intertek assumes no liability to any party, other than to the Client in accordance with the agreement, for any loss, expense or damage occasioned by the use of this report. Only the Client is authorized to permit copying or distribution of this report and then only in its entirety. Any use of the Intertek name or one of its marks for the sale or advertisement of the tested material, product or service must first be approved in writing by Intertek. The observations and test results in this report are relevant only to the sample(s) tested. This report by itself does not imply that the material, product, or service is or has ever been under an Intertek certification program.

TEST REPORT FOR HALLMARK BUILDING SUPPLIES, INC.

Report No.: 103953780SAT-001A

Date: 5/30/19

SECTION 3

TEST METHOD

The specimen was evaluated in accordance with the following:

ASTM E84-19a, *Standard Test Method for Surface Burning Characteristics of Building Materials*

SECTION 4

MATERIAL SOURCE/INSTALLATION

The samples were randomly selected from production stock on 4/1/19 by Intertek representative, Sondra Malone, at the Hallmark Building Supplies manufacturing facility, located at 5121 Frye Road, Suite 100, Irving, TX 75061. Details regarding the composition and traceability of the selected material are included in Intertek Inspection Report [J3219.02-103-15-R0]. The sample, identified as Interlocking panels, Model LDC-419, was received in good order at the Evaluation Center on 5/8/19 and given identification number SAT1905080818-001.

The subject test specimen is a traceable sample selected from the manufacturer's facility. Intertek selected the specimen and has verified the composition, manufacturing techniques and quality assurance procedures. Details regarding the composition and traceability of the selected material are included in Intertek Inspection Report [J3219.02-103-15-R0].

SECTION 5

LIST OF OBSERVERS

NAME	COMPANY
Joseph Martinez	Intertek B&C
Travis Kolinek	Hallmark Building Supplies

SECTION 6

TEST PROCEDURE

This report describes the results of testing conducted in accordance with ASTM E84-19a; Standard Test Method for Surface Burning Characteristics of Building Materials. The test method is for comparative surface burning behavior of building materials by determining a flame spread index (FSI) and a smoke developed index (SDI). This test is generally applicable to exposed surfaces, such as finish materials for ceilings or walls, provided that the material or assembly of

TEST REPORT FOR HALLMARK BUILDING SUPPLIES, INC.

Report No.: 103953780SAT-001A

Date: 5/30/19

materials, by its own structural quality or the manner in which it is tested and intended for use, is capable of supporting itself in position or being supported during the test period.

“The use of supporting materials on the underside of the test specimen may lower the flame spread index from that which might be obtained if the specimen could be tested without such support. This method may not be appropriate for obtaining comparative surface burning behavior of some cellular plastic materials. Testing of materials that melt, drip, or delaminate to such a degree that the continuity of the flame front is destroyed, results in low flame spread indices that do not relate directly to indices obtained by testing materials that remain in place.” – ASTM E84-19a Section 1.4 – 1.5

The purpose of the method is to determine the relative burning behaviour of the material by observing the flame spread along the specimen. Flame spread and smoke density developed are reported, however, there is not necessarily a relationship between these two measurements.

SECTION 6 (CONTINUED)

TEST PROCEDURE

It is the expressed intent of the test method to provide only comparative measurements of surface flame spread and smoke density of the tested material against measurements for select grade red oak flooring and fiber-cement board when tested under specific fire exposure conditions. The test method exposes a nominal 24-ft (7.32-m) long by 20-in. (508-mm) wide test specimen to a controlled air flow and flaming fire exposure adjusted to produce a specific flame spread distance vs time calibration using select grade red oak flooring.

The test method does not provide information regarding heat transmission through the tested surface, the effect of aggravated flame spread behavior resulting from the proximity of combustible walls and ceilings, or the classification or definition of materials as noncombustible using flame spread index alone.

This standard should be used to measure and describe the properties of materials, products, or assemblies in response to heat and flame under controlled laboratory conditions and should not be used to describe or appraise the fire hazard or fire risk of materials, products, or assemblies under actual fire conditions. However, results of this test may be used as elements of a fire risk assessment which takes into account all of the factors which are pertinent to an assessment of the fire hazard of a particular end use.

There were no deviations from the requirements prescribed in ASTM E84.

TEST REPORT FOR HALLMARK BUILDING SUPPLIES, INC.

Report No.: 103953780SAT-001A

Date: 5/30/19

SECTION 7

TEST SPECIMEN DESCRIPTION

MANUFACTURER*	Hallmark Building Supplies, Inc.
SPECIMEN DESCRIPTION*	Interlocking Panels (Cedar)
CONDITIONING TIME	21 days
SPECIMEN LENGTH	24 ft. 3 in. (Three 97 in. long coated aluminum siding panels)
SPECIMEN WIDTH	21 in. (Four 5.25 in. wide pieces)
THICKNESS	0.07 in.
DEPTH	0.63 in.
TOTAL WEIGHT	60 lbs.
COLOR	Brown
ADHESIVE/COVERAGE RATE	N/A
SIDE TO FLAME*	Finished Side
SUPPORT USED*	Rods
MOUNTING METHOD	Standard
SUBSTRATE USED*	None
CEMENT BOARD	1/4 in. thick fiber cement board was placed on top of the sample.

*From the client's material description and/or instructions

Note: Specimens were conditioned as per the requirements of Section 6.4 of ASTM E84-19a.

TEST REPORT FOR HALLMARK BUILDING SUPPLIES, INC.

Report No.: 103953780SAT-001A

Date: 5/30/19

SECTION 8

TEST RESULTS

TEST RESULTS	
Test Date	5/29/19
Test Operator	Joseph Martinez
Flame Spread Index (FSI)	0
Smoke Developed Index (SDI)	5
Heptane Calibration (% * Min)	76.8

TEST DATA	
FSI (unrounded)	0.0
SDI (unrounded)	6.9
FS * Time Area (Ft * Min)	0.0
Smoke Area (% * Min)	5.3
Total Fuel Burned (Cubic Ft.)	43.24
Max Flame Front Advance (Ft.)	0.0
Time to Max Flame Front (sec)	0
Max Temp At Exposed T/C (°F)	519
Time To Max Temp (sec)	594

TEST OBSERVATIONS	
Ignition Time	1:36
Observations After the Test:	
0 – 4 ft.	The coating was heavily charred and cracked.
4 – 6 ft.	The coating was heavily discolored.
6 – 24 ft.	No visible damage.

TEST REPORT FOR HALLMARK BUILDING SUPPLIES, INC.

Report No.: 103953780SAT-001A

Date: 5/30/19

SECTION 8 (Continued)

TEST RESULTS

COMMENTARY ON CLASSIFICATION

Neither ASTM E84 nor UL 723 include classification criteria for the results obtained from testing. The International Building Code® (IBC), NFPA 101: Life Safety Code® (NFPA 101), and NFPA 5000: Building Construction and Safety Code® (NFPA 5000) all describe a set of classification criteria required for interior wall and ceiling finish materials based on Flame Spread Index and Smoke Developed Index when tested in accordance with ASTM E84 or UL 723. The classification criteria for all three model codes is the same:

Class	Flame Spread Index	Smoke Developed Index
A	0-25	0-450
B	26-75	0-450
C	76-200	0-450

Note that classification under this scheme for interior wall and ceiling finishes does not strictly apply to all products or materials tested in accordance with ASTM E84 or UL 723 because not all products or materials are recommended or suitable for use as interior wall or ceiling finish materials in buildings, regardless of the surface burning characteristics. Consult with the product manufacturer and the local authority having jurisdiction (AHJ) regarding specific applications of a given product or material.

TEST REPORT FOR HALLMARK BUILDING SUPPLIES, INC.

Report No.: 103953780SAT-001A

Date: 5/30/19

SECTION 9 PHOTOGRAPHS



Photo No. 1
Inspector's Initials



Photo No. 2
Exposed Surface of the Test Specimen (Pre-test)

TEST REPORT FOR HALLMARK BUILDING SUPPLIES, INC.

Report No.: 103953780SAT-001A

Date: 5/30/19

SECTION 9 (Continued) PHOTOGRAPHS

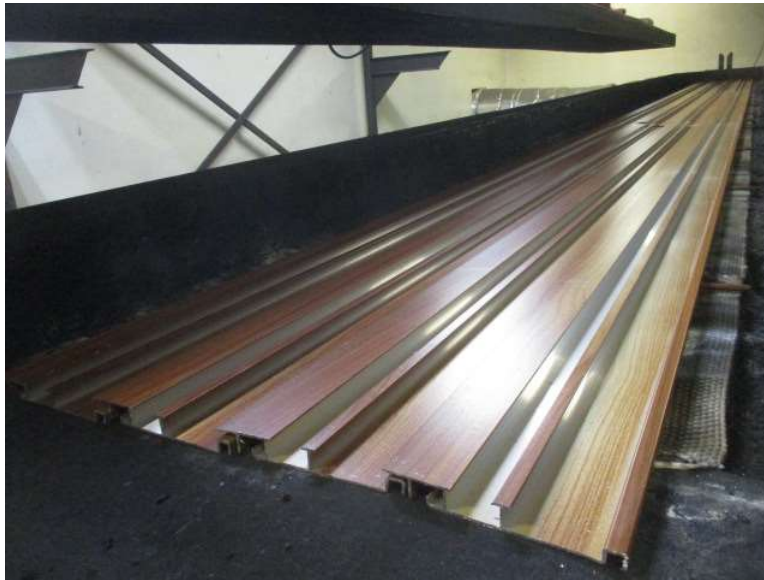

Photo No. 3
Unexposed Surface of the Test Specimen (Pre-test)



Photo No. 4
Unexposed Surface of the Test Specimen (Post-test)

TEST REPORT FOR HALLMARK BUILDING SUPPLIES, INC.

Report No.: 103953780SAT-001A

Date: 5/30/19

SECTION 9 (Continued)

PHOTOGRAPHS



Photo No. 5

Exposed Surface of the Test Specimen (Post-test)

TEST REPORT FOR HALLMARK BUILDING SUPPLIES, INC.

Report No.: 103953780SAT-001A

Date: 5/30/19

SECTION 10

GRAPHS

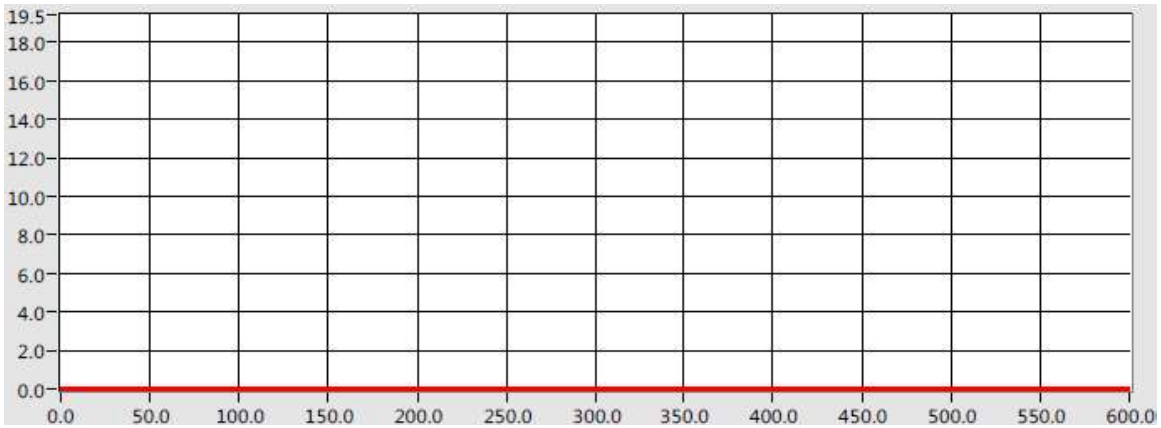

Graph No. 1 - Flame Spread Distance Versus Time

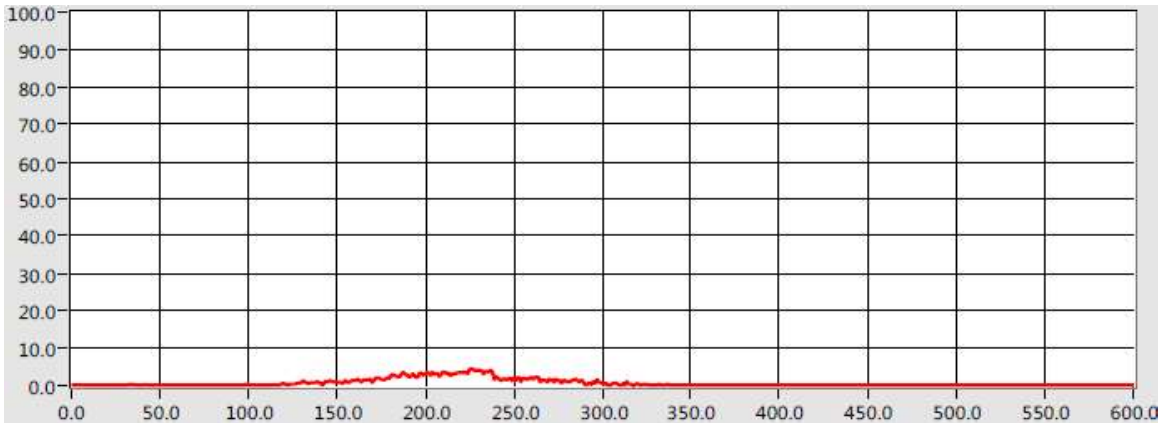

Graph No. 2 - Light Obscuration Versus Time

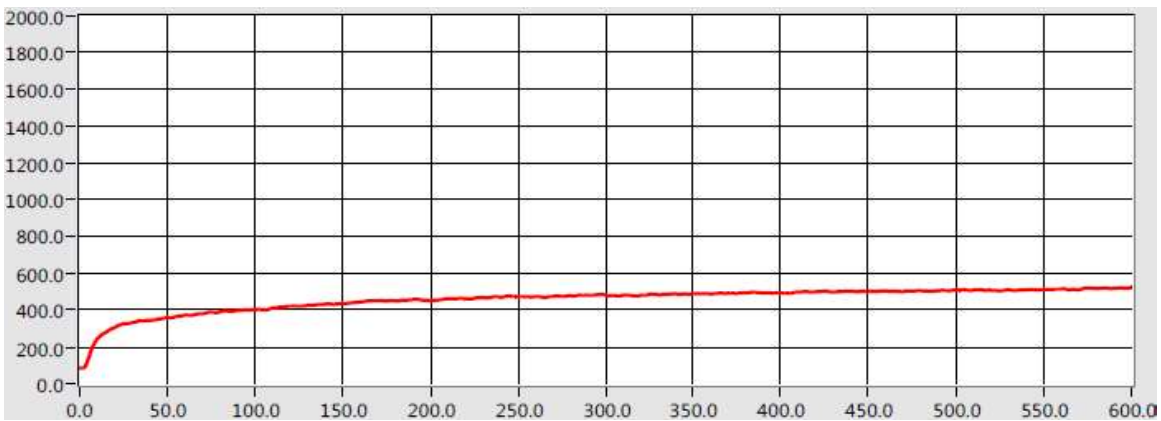

Graph No. 3 - Tunnel Air Temperature Versus Time



Total Quality. Assured.

16015 Shady Falls
Elmendorf, Texas 78112

Telephone: 210-635-8100
Facsimile: 210-635-8101
www.intertek.com/building

TEST REPORT FOR HALLMARK BUILDING SUPPLIES, INC.

Report No.: 103953780SAT-001A

Date: 5/30/19

SECTION 11

REVISION LOG

REVISION #	DATE	PAGES	REVISION
0	5/30/19	N/A	Original Report Issue

HALLMARK BUILDING SUPPLIES, INC. WINDLOAD TEST REPORT

SCOPE OF WORK

ASTM D5206 WINDLOAD TESTING ON LDC-619 INTERLOCKING PANELS, LEVANTE SIDING

REPORT NUMBER

J3219.04-109-40

TEST DATE(S)

06/26/19 - 06/27/19

ISSUE DATE

09/09/19

RECORD RETENTION END DATE

06/27/23

PAGES

10

DOCUMENT CONTROL NUMBER

ATI 00500 (07/24/17)

RT-R-AMER-Test-2808

© 2017 INTERTEK

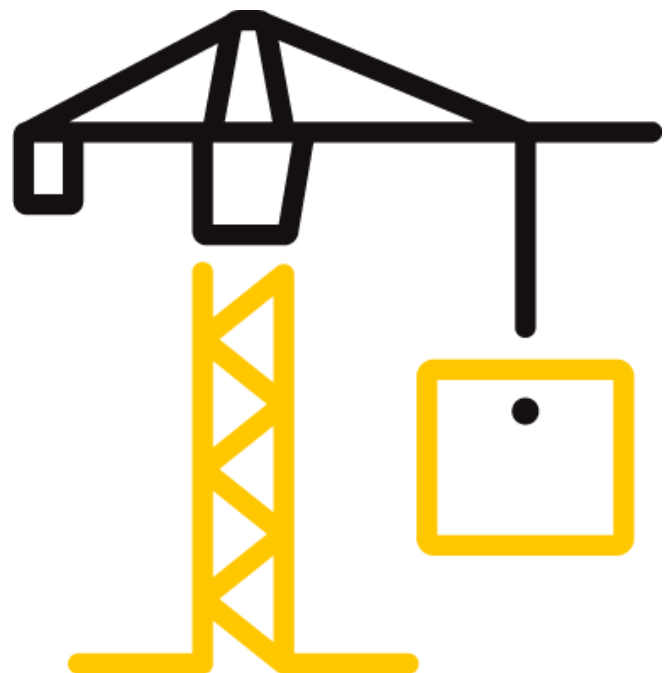

TEST REPORT FOR HALLMARK BUILDING SUPPLIES, INC.

Report No.: J3219.04-109-40

Date: 09/09/19

REPORT ISSUED TO

HALLMARK BUILDING SUPPLIES, INC.

2120 Pewaukee Road, Suite 100

Waukesha, Wisconsin 53188

SECTION 1

SCOPE

Intertek Building & Construction (B&C) was contracted by Hallmark Building Supplies, Inc. to perform windload testing in accordance with ASTM D5206 on their LDC-619 Interlocking Panels, Levante Siding. Results obtained are tested values and were secured by using the designated test method. Testing was conducted at the Intertek B&C test facility in York, Pennsylvania.

This report does not constitute certification of this product nor an opinion or endorsement by this laboratory.

SECTION 2

SUMMARY OF TEST RESULTS

Product Type: Siding

Series/Model: LDC-619 Interlocking Panels, Levante

Average Maximum Sustained Negative Pressure: 125.0 psf

Average Ultimate Negative Test Pressure: 130.0 psf

For INTERTEK B&C:

COMPLETED BY:	John A. Shanabrook	REVIEWED BY:	Timothy J. McGill
TITLE:	Technician – Product Testing	TITLE:	Manager – Product Testing
SIGNATURE:	 <small>Digitally Signed by: John Shanabrook</small>	SIGNATURE:	 <small>Digitally Signed for: Timothy J. McGill by Vicki L. McElwain</small>
DATE:	09/09/19	DATE:	09/09/19

JAS:wnl

This report is for the exclusive use of Intertek's Client and is provided pursuant to the agreement between Intertek and its Client. Intertek's responsibility and liability are limited to the terms and conditions of the agreement. Intertek assumes no liability to any party, other than to the Client in accordance with the agreement, for any loss, expense or damage occasioned by the use of this report. Only the Client is authorized to permit copying or distribution of this report and then only in its entirety. Any use of the Intertek name or one of its marks for the sale or advertisement of the tested material, product or service must first be approved in writing by Intertek. The observations and test results in this report are relevant only to the sample(s) tested. This report by itself does not imply that the material, product, or service is or has ever been under an Intertek certification program.

TEST REPORT FOR HALLMARK BUILDING SUPPLIES, INC.

Report No.: J3219.04-109-40

Date: 09/09/19

SECTION 3

TEST METHOD(S)

The specimen was evaluated in accordance with the following:

ASTM D5206-13, *Standard Test Method for Windload Resistance of Rigid Plastic Siding*

SECTION 4

MATERIAL SOURCE/INSTALLATION

The specimens were selected by Intertek B&C personnel. The specimens were witnessed during production and tagged prior to shipment on 04/01/19, (Reference Intertek B&C Test Specimen Selection Report No. J3219.02-103-15, dated 04/01/19). Representative samples of the test specimens will be retained by Intertek B&C for a minimum of four years from the test completion date.

The specimen was installed into test buck measuring 4' 1-1/2" wide by 6' high constructed of #2 Spruce-Pine-Fir nominal 2x4 lumber. Two studs were spaced 16" on center (three spans) and were attached to the top and bottom plates with 3" long drywall screws. The right center stud was reinforced with an additional nominal 2x4 stud sistered into place per client request. A sheet of nominal 1/2" thick OSB, with five 4" diameter holes to allow pressure to transfer to the siding, was secured to the studs with #8 x 1-5/8" drywall screws. Silicone was utilized on the backside of the test panel to seal the perimeter. A 2-mil thick plastic film was loosely draped over the interior of the siding to enable attainment of pressure.

The siding was mounted with #8 x 1-5/8" lath self-tapping screws, spaced 16" on center through the sheathing and into the studs.

SECTION 5

EQUIPMENT

Tape Measure Verification: 63788

Control Panel: 005406

Weather Station: 63316

SECTION 6

LIST OF OFFICIAL OBSERVERS

NAME	COMPANY
Michael Hoium	Hallmark Building Supplies, Inc.
Timothy J. McGill	Intertek B&C
John A. Shanabrook	Intertek B&C

TEST REPORT FOR HALLMARK BUILDING SUPPLIES, INC.

Report No.: J3219.04-109-40

Date: 09/09/19

SECTION 7

TEST SPECIMEN DESCRIPTION

MANUFACTURER	Levanté, LLC
SERIES/MODEL	LDC-619 Interlocking Panels, Levante
PRODUCT TYPE	Aluminum siding
MATERIAL TYPE	Aluminum
NOMINAL THICKNESS	0.071"
MEASURED THICKNESS	0.079"
NAIL HEM TYPE	Flat
NAIL HEM THICKNESS	0.075"
EXTERIOR FINISH	Flat

Each specimen consisted of four horizontal courses of siding with a male interlock on the bottom and a female interlock on the top. An aluminum starter strip was utilized the length of the bottom plate. A vertical transition strip was installed in the second and third courses over the sistered stud.

SECTION 8

TEST RESULTS

The temperature during testing was 29°C - 31°C (85°F - 87°F). The results are tabulated as follows:

General Note: *All loads were negative pressure and were held for thirty seconds. A 5.0 psf pre-load was applied before running specimens to failure.*

Test Specimen #1:

PRESSURE	RESULTS
10.0 psf to 125.0 psf	No damage
130.0 psf	Testing stopped due to the wall design

Test Specimen #2:

PRESSURE	RESULTS
10.0 psf to 125.0 psf	No damage
130.0 psf	Testing stopped due to the wall design

TEST REPORT FOR HALLMARK BUILDING SUPPLIES, INC.

Report No.: J3219.04-109-40

Date: 09/09/19

Test Specimen #3:

PRESSURE	RESULTS
10.0 psf to 125.0 psf	No damage
130.0 psf	Testing stopped due to the wall design

SECTION 9

CONCLUSION

The specimens tested successfully achieved an Average Maximum Sustained Negative Pressure of 125.0 psf and an Average Ultimate Negative Test Pressure of 130.0 psf.

Testing was stopped due to pressure limits on the testing buck being reached.

TEST REPORT FOR HALLMARK BUILDING SUPPLIES, INC.

Report No.: J3219.04-109-40

Date: 09/09/19

SECTION 10

PHOTOGRAPHS

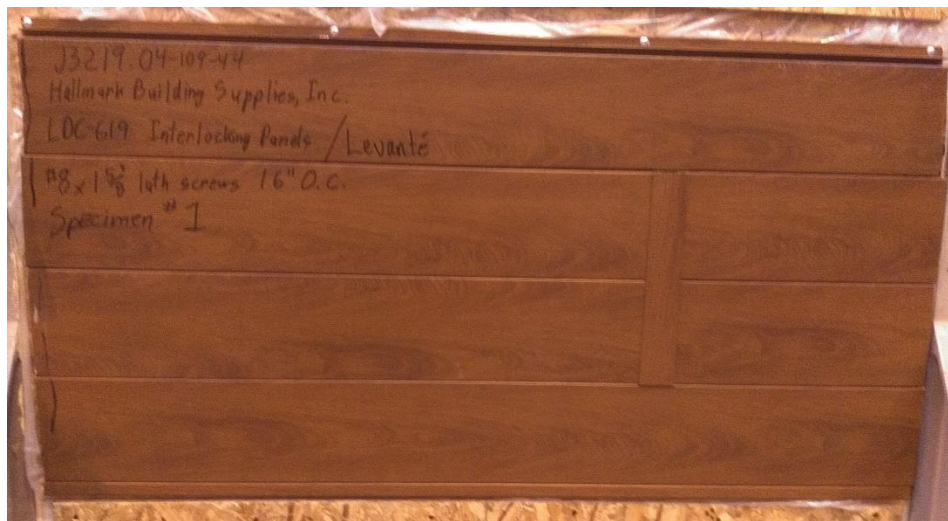

Photo No. 1
Specimen #1 Prior to Testing



Photo No. 2
Specimen #2 Prior to Testing

TEST REPORT FOR HALLMARK BUILDING SUPPLIES, INC.

Report No.: J3219.04-109-40

Date: 09/09/19



Photo No. 3
Specimen #3 Prior to Testing



Total Quality. Assured.

130 Derry Court
York, Pennsylvania 17406

Telephone: 717-764-7700
Facsimile: 717-764-4129
www.intertek.com/building

TEST REPORT FOR HALLMARK BUILDING SUPPLIES, INC.

Report No.: J3219.04-109-40

Date: 09/09/19

SECTION 11 DRAWINGS

The test specimen drawings have been reviewed by Intertek B&C and are representative of the test specimens reported herein. Test specimen construction was verified by Intertek B&C per the drawings included in this report. Any deviations are documented herein or on the drawings.

intertek
Total Quality Assured.

Report #: J3219.04
Date: 7/01/2019
Verified by: John A. Sharabook

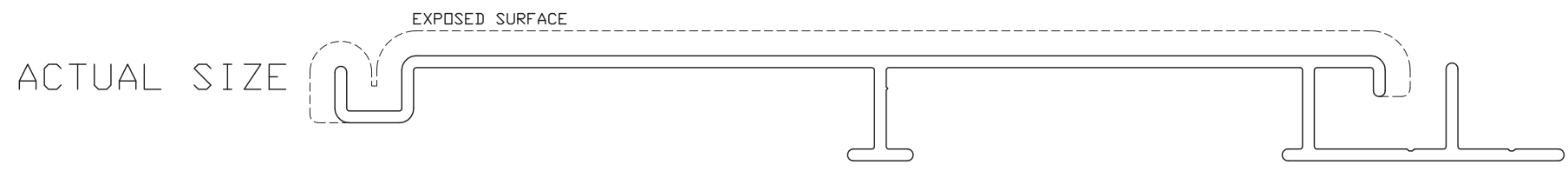
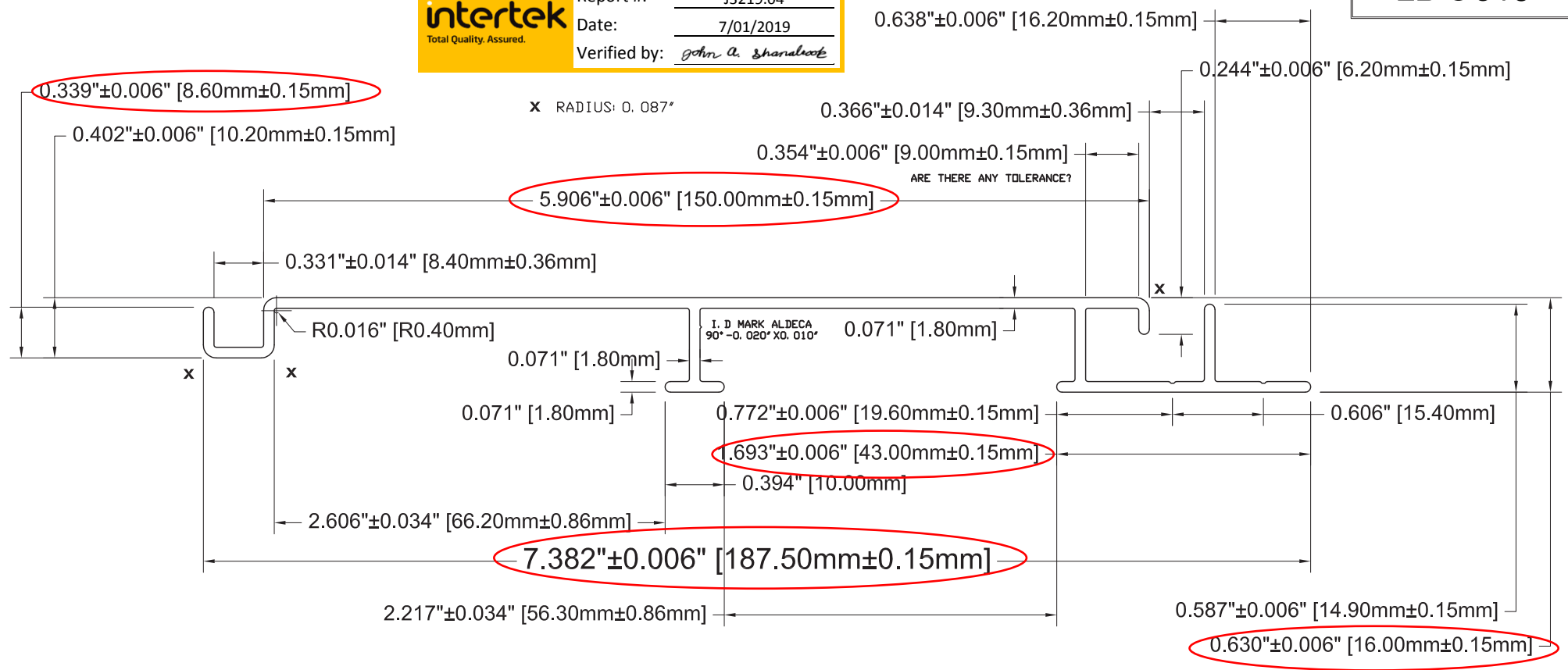

Est. Area	: 0.745	Sq/In.
Est. WT/FT	: 0.876	LBS.
Est. Perimeter	: -----	Inches
OutSide Perimeter	: 21.026	Inches
Circum Circle	: 7.409	Inches
Factor	: 24.003	

UNLESS OTHERWISE SPECIFIED

TYPICAL WALL THICKNESS : 0.071"
BREAK SHARP CORNERS : 0.016"
ALL DIMENSIONS ARE : Inches

ESCALE : 1 : 1
DETAILS : 0.00 : 0

CUSTOMER: LEVANTÉ

ALUMINUM ASSOCIATION STANDARD FOR EXTRUDED SHAPES APPLY UNLESS SPECIFICALLY SHOWN OTHERWISE.			
INGDT	PZS.		ALLOY: 6 0 6 3
7"			TEMPER: T 5
8"			

DRAWING : Arq. Victor Flores - 18/12/17
REVISED: Arq. Victor Flores
DATE: 18 / 12 / 17

CLASSIFICATION

SOLID
SEMI-HOLLOW
HOLLOW

NAME :
INTERLOCKING BOARD
APROX. 6" (150MM)



LDC619



Total Quality. Assured.

130 Derry Court
York, Pennsylvania 17406

Telephone: 717-764-7700
Facsimile: 717-764-4129
www.intertek.com/building

TEST REPORT FOR HALLMARK BUILDING SUPPLIES, INC.

Report No.: J3219.04-109-40

Date: 09/09/19

SECTION 12

REVISION LOG

REVISION #	DATE	PAGES	REVISION
0	09/09/19	N/A	Original Report Issue

HALLMARK BUILDING SUPPLIES, INC. TEST REPORT

SCOPE OF WORK

MODIFIED FM 4473 IMPACT RESISTANCE TESTING OF LEVANTE, INTERLOCKING BOARDS

REPORT NUMBER

M4644.01-109-44

TEST DATE(S)

07/19/21

ISSUE DATE

08/12/21

RECORD RETENTION END DATE

07/19/25

PAGES

15

DOCUMENT CONTROL NUMBER

ATI 00371 (08/24/17)

RT-R-AMER-Test-2957

© 2017 INTERTEK

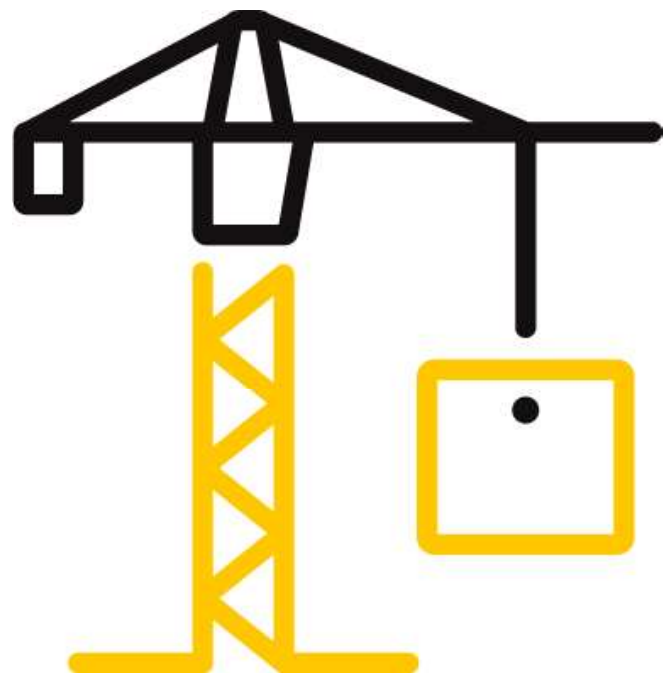

TEST REPORT FOR HALLMARK BUILDING SUPPLIES, INC.

Report No.: M4644.01-109-44

Date: 08/12/21

REPORT ISSUED TO

HALLMARK BUILDING SUPPLIES, INC.

901 Northview Road

Suite 100

Waukesha, Wisconsin 53188

SECTION 1

SCOPE

Architectural Testing, Inc. (an Intertek company) dba Intertek Building & Construction (B&C) was contracted by Hallmark Building Supplies, Inc. to perform testing in general accordance with FM 4473 on their Levante, interlocking boards. Results obtained are tested values and were secured by using the designated test method(s). Testing was conducted at the Intertek B&C test facility in York, Pennsylvania.

For INTERTEK B&C:

COMPLETED BY:	Richard E. Hartman III	REVIEWED BY:	Vicki L. McElwain
TITLE:	Technician – Product Testing	TITLE:	Supervisor – Product Testing
SIGNATURE:	 <small>Digitally Signed by: Richard Hartman III</small>	SIGNATURE:	 <small>Digitally Signed by: Vicki L. McElwain</small>
DATE:	08/12/21	DATE:	08/12/21

REH:nls

This report is for the exclusive use of Intertek's Client and is provided pursuant to the agreement between Intertek and its Client. Intertek's responsibility and liability are limited to the terms and conditions of the agreement. Intertek assumes no liability to any party, other than to the Client in accordance with the agreement, for any loss, expense or damage occasioned by the use of this report. Only the Client is authorized to permit copying or distribution of this report and then only in its entirety. Any use of the Intertek name or one of its marks for the sale or advertisement of the tested material, product or service must first be approved in writing by Intertek. The observations and test results in this report are relevant only to the sample(s) tested. This report by itself does not imply that the material, product, or service is or has ever been under an Intertek certification program.

TEST REPORT FOR HALLMARK BUILDING SUPPLIES, INC.

Report No.: M4644.01-109-44

Date: 08/12/21

SECTION 2

TEST METHOD(S)

The specimen was evaluated in general accordance with the following:

Modified ANSI/FM 4473 (2011), *Specification Test Standard for Impact Resistance Testing of Rigid Roofing Materials by Impacting with Freezer Ice Balls*. American National Standard, FM Approvals (January 2011).

SECTION 3

MATERIAL SOURCE/INSTALLATION

Test specimen(s) was provided by the client. Representative samples of the test specimen(s) will be retained by Intertek B&C for a minimum of four years from the test completion date.

Installation of the tested product was performed by the Intertek B&C. The specimen was placed on a wood test deck and was secured with #8 x 1-5/8" pan head screws located 16" on center through the panels and into the studs. The panels interlocked and overlapped 7/16" at the top and bottom.

SECTION 4

EQUIPMENT

Cannon: Constructed from steel piping utilizing compressed air to propel the missile

Missile: 44.5 mm (1-3/4") and 50.8 mm (2.0") diameter ice balls

Cannon Identification Number: A1207

Timing Device: Electronic Beam Type

Timing Device Calibration Date: 8/18/21

Tape Measure Verification: 63788

Weather Station: 63316

SECTION 5

LIST OF OFFICIAL OBSERVERS

NAME	COMPANY
Caitlin Kittle	Hallmark Building Supplies, Inc.
Vicki L. McElwain	Intertek B&C
Richard E. Hartman III	Intertek B&C

TEST REPORT FOR HALLMARK BUILDING SUPPLIES, INC.

Report No.: M4644.01-109-44

Date: 08/12/21

SECTION 6

TEST SPECIMEN DESCRIPTION

Product Type: Interlocking Boards

Series/Model: Levante

Color: Brown

Finish: Wood Grain

Overall Assembly Size: 1219 mm (48") width by 949 mm (37-3/8") length

Nominal Thickness: 1.8 mm (0.069")

Tile Description: Extruded aluminum with a male interlock at the bottom and a female interlock at the top

Individual Tile Weight: 1500 g (3.3 lb)

Individual Tile Size: 1219 mm (48") width by 187 mm (7-3/8") length

Exposed Tile Size: 1219 mm (48") width by 149 mm (5-7/8") length

Number of Tiles: 6

Deck Construction:

The wood test deck was 4' wide x 3' high and was constructed from 2x4 Spruce-Pine-Fir construction lumber at the perimeter with three studs spaced 16" on center.

Panel Construction:

The panels were constructed from extruded aluminum. An extruded aluminum starter strip was utilized.



Total Quality. Assured.

130 Derry Court
York, Pennsylvania 17406

Telephone: 717-764-7700
Facsimile: 717-764-4129
www.intertek.com/building

TEST REPORT FOR HALLMARK BUILDING SUPPLIES, INC.

Report No.: M4644.01-109-44

Date: 08/12/21

SECTION 7 TEST RESULTS

Modified FM 4473, Ice Ball Impact Resistance

Sample Conditioning Temperature: 26°C (79°F) for at least 4 hours

Sample Conditioning Relative Humidity: 59% for at least 4 hours

Ice Ball Conditioning Temperature: -22°C (-7°F) for at least 48 hours

Muzzle Distance from Test Specimen: 1524 mm (60")

The ambient temperature during testing was 27°C (80°F). The results are tabulated as follows.

Class 3 Ice Ball Impacts:

LOCATION/ IMPACT	VELOCITY m/s (fps)	ORIENTATION	MISSILE		DIAMETER mm (in.)	ENERGY ft-lb	IMPACT AREA	OBSERVATIONS	RESULTS
			WEIGHT g (lbs)	WEIGHT g (lbs)					
1 - 1	30.5 (100.0)	15° of vertical	43.0 (0.095)	43.0 (0.095)	44.5 (1.75)	14.73	Left side, center edge of panel	No visible cracking or breakage	Pass
1 - 2	30.4 (99.8)	15° of vertical	42.1 (0.093)	42.1 (0.093)	44.5 (1.75)	14.37	Left side, center edge of panel	No visible cracking or breakage	Pass
2 - 1	30.7 (100.6)	15° of vertical	43.0 (0.095)	43.0 (0.095)	44.5 (1.75)	14.91	Top left corner, edge of panel	No visible cracking or breakage	Pass
2 - 2	30.6 (100.3)	15° of vertical	42.1 (0.093)	42.1 (0.093)	44.5 (1.75)	14.51	Top left corner, edge of panel	No visible cracking or breakage	Pass
3 - 1	30.1 (98.7)	15° of vertical	42.1 (0.093)	42.1 (0.093)	44.5 (1.75)	14.05	Bottom of panel next to stud	No visible cracking or breakage	Pass
3 - 2	30.1 (98.7)	15° of vertical	43.0 (0.095)	43.0 (0.095)	44.5 (1.75)	14.35	Bottom of panel next to stud	No visible cracking or breakage	Pass



Total Quality. Assured.

130 Derry Court
York, Pennsylvania 17406

Telephone: 717-764-7700
Facsimile: 717-764-4129
www.intertek.com/building

TEST REPORT FOR HALLMARK BUILDING SUPPLIES, INC.

Report No.: M4644.01-109-44

Date: 08/12/21

Class 3 Ice Ball Impacts: (Continued)

LOCATION/ IMPACT	VELOCITY m/s (fps)	ORIENTATION	MISSILE		ENERGY ft-lb	IMPACT AREA	OBSERVATIONS	RESULTS
			WEIGHT g (lbs)	DIAMETER mm (in.)				
4 - 1	30.1 (98.7)	15° of vertical	42.1 (0.093)	44.5 (1.75)	14.05	Bottom of panel, between studs, at interlock	No visible cracking or breakage	Pass
4 - 2	30.2 (99.0)	15° of vertical	44.0 (0.097)	44.5 (1.75)	14.78	Bottom of panel, between studs, at interlock	No visible cracking or breakage	Pass
5 - 1	30.3 (99.3)	15° of vertical	42.1 (0.093)	44.5 (1.75)	14.22	Center of panel, between studs	No visible cracking or breakage	Pass
5 - 2	30.5 (100.0)	15° of vertical	43.0 (0.095)	44.5 (1.75)	14.73	Center of panel, between studs	No visible cracking or breakage	Pass
6 - 1	30.1 (98.9)	15° of vertical	42.1 (0.093)	44.5 (1.75)	14.11	Center of panel, next to stud	No visible cracking or breakage	Pass
6 - 2	30.7 (100.6)	15° of vertical	42.1 (0.093)	44.5 (1.75)	14.60	Center of panel, next to stud	No visible cracking or breakage	Pass
7 - 1	30.8 (101.1)	15° of vertical	42.1 (0.093)	44.5 (1.75)	14.74	Bottom of panel, next to stud, at interlock	No visible cracking or breakage	Pass
7 - 2	31.3 (102.7)	15° of vertical	42.1 (0.093)	44.5 (1.75)	15.22	Bottom of panel, next to stud, at interlock	No visible cracking or breakage	Pass
8 - 1	31.5 (103.3)	15° of vertical	42.1 (0.093)	44.5 (1.75)	15.39	Center of panel, next to stud	No visible cracking or breakage	Pass
8 - 2	30.7 (100.6)	15° of vertical	42.1 (0.093)	44.5 (1.75)	14.60	Center of panel, next to stud	No visible cracking or breakage	Pass

TEST REPORT FOR HALLMARK BUILDING SUPPLIES, INC.

Report No.: M4644.01-109-44

Date: 08/12/21

Class 3 Ice Ball Impacts: (Continued)

LOCATION/ IMPACT	MISSILE			ENERGY ft-lb	IMPACT AREA	OBSERVATIONS	RESULTS
	VELOCITY m/s (fps)	ORIENTATION	WEIGHT g (lbs)				
9 - 1	30.3 (99.5)	15° of vertical	42.1 (0.093)	14.28	Bottom of panel, between studs, at interlock	No visible cracking or breakage	Pass
9 - 2	31.0 (101.6)	15° of vertical	42.1 (0.093)	14.89	Bottom of panel, between studs, at interlock	No visible cracking or breakage	Pass
10 - 1	30.1 (98.6)	15° of vertical	42.1 (0.093)	14.02	Center of panel, between studs	No visible cracking or breakage	Pass
10 - 2	30.3 (99.5)	15° of vertical	42.1 (0.093)	14.28	Center of panel, between studs	No visible cracking or breakage	Pass
11 - 1	29.9 (98.0)	15° of vertical	43.0 (0.095)	14.15	Right side, center edge of panel	No visible cracking or breakage	Pass
11 - 2	29.8 (97.8)	15° of vertical	43.0 (0.095)	14.09	Right side, center edge of panel	No visible cracking or breakage	Pass
12 - 1	31.1 (102.0)	15° of vertical	43.0 (0.095)	15.33	Top right corner, edge of panel	No visible cracking or breakage	Pass
12 - 2	31.4 (103.1)	15° of vertical	42.1 (0.093)	15.33	Top right corner, edge of panel	No visible cracking or breakage	Pass



Total Quality. Assured.

130 Derry Court
York, Pennsylvania 17406

Telephone: 717-764-7700
Facsimile: 717-764-4129
www.intertek.com/building

TEST REPORT FOR HALLMARK BUILDING SUPPLIES, INC.

Report No.: M4644.01-109-44

Date: 08/12/21

Class 4 Ice Ball Impacts:

LOCATION/ IMPACT	VELOCITY m/s (fps)	MISSILE		ENERGY ft-lb	IMPACT AREA	OBSERVATIONS	RESULTS
		ORIENTATION	WEIGHT g (lbs)				
1 - 1	32.2 (105.5)	15° of vertical	63.0 (0.139)	24.03	Left side, bottom edge of panel	No visible cracking or breakage	Pass
1 - 2	32.5 (106.7)	15° of vertical	65.0 (0.143)	25.36	Left side, bottom edge of panel	No visible cracking or breakage	Pass
2 - 1	32.7 (107.3)	15° of vertical	63.0 (0.139)	24.85	Top of panel, next to stud	No visible cracking or breakage	Pass
2 - 2	31.6 (103.8)	15° of vertical	65.0 (0.143)	24.00	Top of panel, next to stud	No visible cracking or breakage	Pass
3 - 1	32.5 (106.7)	15° of vertical	63.0 (0.139)	24.58	Center of panel, between studs	Small indentation	Pass
3 - 2	33.3 (109.1)	15° of vertical	64.0 (0.141)	26.10	Center of panel, between studs	No additional damage	Pass
4 - 1	33.3 (109.1)	15° of vertical	63.0 (0.139)	25.69	Bottom of panel, next to stud	Small indentation	Pass
4 - 2	32.5 (106.7)	15° of vertical	65.0 (0.143)	25.36	Bottom of panel, next to stud	Small indentation	Pass
5 - 1	32.7 (107.3)	15° of vertical	63.0 (0.139)	24.85	Bottom of panel, between studs, at interlock	No visible cracking or breakage	Pass
5 - 2	31.6 (103.8)	15° of vertical	65.0 (0.143)	24.00	Bottom of panel, between studs, at interlock	No visible cracking or breakage	Pass



Total Quality. Assured.

130 Derry Court
York, Pennsylvania 17406

Telephone: 717-764-7700
Facsimile: 717-764-4129
www.intertek.com/building

TEST REPORT FOR HALLMARK BUILDING SUPPLIES, INC.

Report No.: M4644.01-109-44

Date: 08/12/21

Class 4 Ice Ball Impacts: (Continued)

LOCATION/ IMPACT	VELOCITY m/s (fps)	MISSILE			ENERGY ft-lb	IMPACT AREA	OBSERVATIONS	RESULTS
		ORIENTATION	WEIGHT g (lbs)	DIAMETER mm (in.)				
6 - 1	32.0 (105.1)	15° of vertical	63.0 (0.139)	50.8 (2.00)	23.85	Right side, bottom edge of panel, at interlock	No visible cracking or breakage	Pass
6 - 2	32.4 (106.2)	15° of vertical	63.0 (0.139)	50.8 (2.00)	24.35	Right side, bottom edge of panel, at interlock	No visible cracking or breakage	Pass

SECTION 8 CONCLUSION

The sample tested showed no evidence of visible cracking, breakage, splits, punctures, or disengagement of lap elements.

This report does not constitute certification of this product nor an opinion or endorsement by this laboratory. Intertek B&C will service this report for the entire test record retention period. The test record retention period ends four years after the test date. Test records, such as detailed drawings, datasheets, representative samples of test specimens, or other pertinent project documentation, will be retained for the entire test record retention period.

Unless differently required, Intertek reports apply the "Simple Acceptance" rule, also called "Shared Risk approach," of ILAC-G8:09/2019, Guidelines on Decision Rules and Statements of Conformity.

TEST REPORT FOR HALLMARK BUILDING SUPPLIES, INC.

Report No.: M4644.01-109-44

Date: 08/12/21

SECTION 9 SKETCH(ES)

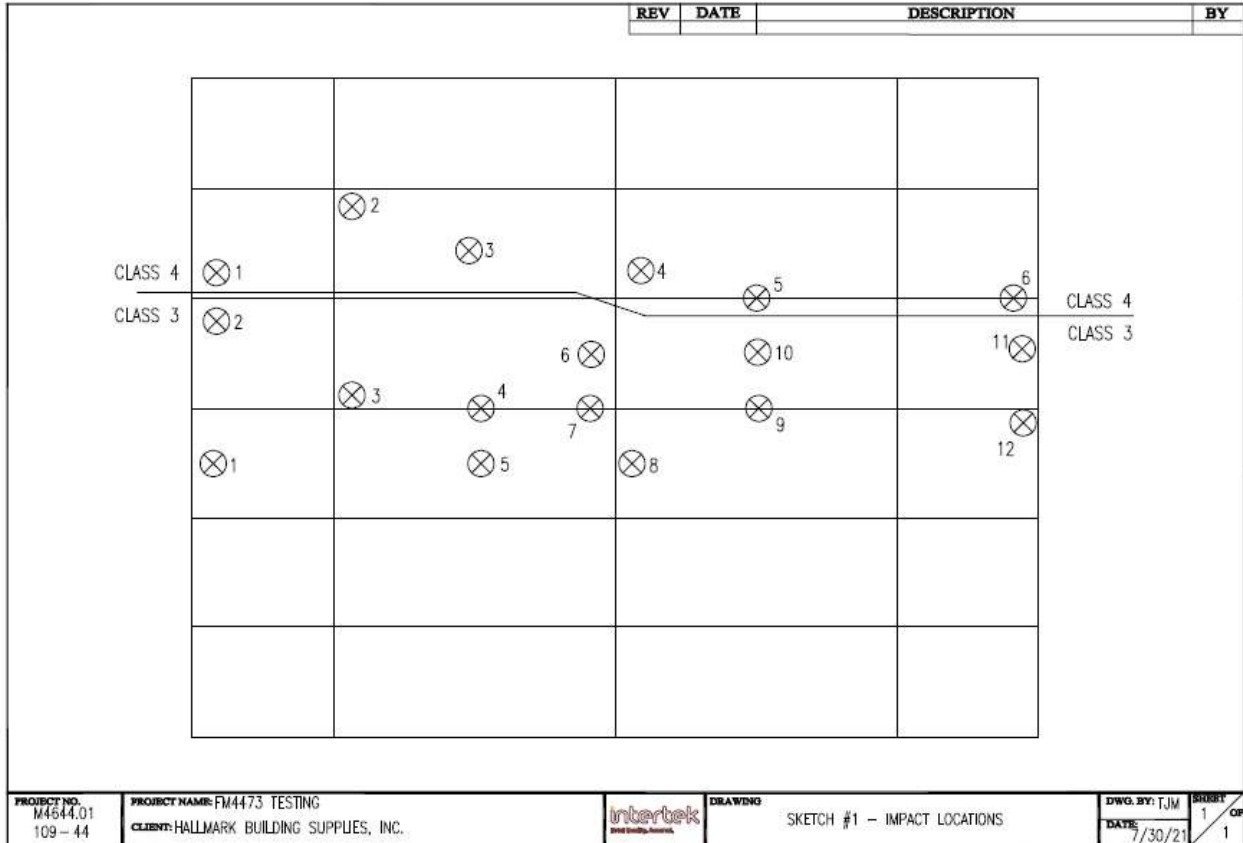

**Sketch No. 1
Impact Locations**

TEST REPORT FOR HALLMARK BUILDING SUPPLIES, INC.

Report No.: M4644.01-109-44

Date: 08/12/21

SECTION 10 PHOTOGRAPH



Photo No. 1
View of Test Specimen Prior to Impacts with Stud Spacing Marked



Total Quality. Assured.

130 Derry Court
York, Pennsylvania 17406

Telephone: 717-764-7700
Facsimile: 717-764-4129
www.intertek.com/building

TEST REPORT FOR HALLMARK BUILDING SUPPLIES, INC.

Report No.: M4644.01-109-44

Date: 08/12/21

SECTION 1 DRAWINGS

The test specimen drawings have been reviewed by Intertek B&C and are representative of the test specimen(s) reported herein. Test specimen construction was verified by Intertek B&C per the drawings included in this report. Any deviations are documented herein or on the drawings.

8 7 6 5 4 3 2 1



LEVANTÉ LLC
 901 NORTHVIEW ROAD
 SUITE 100
 WAUKESHA, WISCONSIN 53188

Project Name:

Part Name:
 150mm - 6" INTERLOCKING BOARD

Used on assembly:

Part No.:
 LDC619
 Drawing Number:
 AL-13689-D

REVISIONS

REV.	DESCRIPTION	DATE	APPROVED
B	DIMENSION INDICATED BY A RED LETTER 'B' HAS BEEN MODIFIED FROM 0.587" [14.90mm] TO 0.557" [14.15mm]. SLOT CUTS HAVE BEEN ADDED ALONG PROFILE'S LENGTH.	4/17/2020	EASS
C	LOCATION OF SLOT HOLES HAVE BEEN MODIFIED TO BE ALONG V-GROOVE SECTION. NUMBER OF SLOT HOLE ROWS WAS DECREASED FROM TWO ROWS TO ONE ROW.	5/14/2020	EASS
D	SLOT WIDTH HAS BEEN DECREASED FROM 0.197" [5.00mm] TO 0.1695" [4.30mm]; SLOT LENGTH HAS BEEN MODIFIED FROM 0.591" [15.00mm] TO 0.661" [16.80mm]; TYPICAL SPACING BETWEEN EACH SLOT HAS BEEN MODIFIED FROM 0.986" [25.05mm] FROM SLOTS EDGES TO 4.000" [101.60mm] FROM SLOT CENTERS; FIRST AND LAST SLOT STARTS/TENDS 1.000" [25.40mm] FROM EDGES.	6/1/2020	EASS

intertek
 Total Quality. Assured.

Report #: M4644.01
 Date: 7/22/2021
 Verified by: *Robert E. Hester*

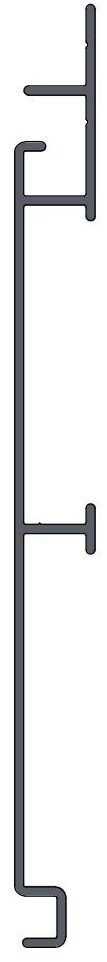

EXTRUSION PROFILE
 SCALE 1:1

F E D C B A

8 7 6 5 4 3 2 1

4

3

2

1

NOTES:

1. EXTRUSION SHALL BE STRAIGHT WITHIN 1.1mm PER 1M [0.015'/FOOT]
2. EXTRUSION TWIST 1.0DEG PER 1M [1.0DEG/FOOT]
3. EXTRUSION CROSS SECTIONAL AREA IS 0.7451 sq.in. [480.72mm sq.]
4. ALL RADI & FILLET RADIUS TO BE R0.016" [0.40mm] UNLESS OTHERWISE SPECIFIED
5. SECTIONAL MATERIAL THICKNESS 0.071" [1.80mm] UNLESS OTHERWISE SPECIFIED
6. CRITICAL DIMENSIONS ARE SHOWN WITHIN \varnothing
7. REFERENCE DIMENSIONS ARE SHOWN WITHIN ()
8. ALL DIMENSIONS INCLUDE SURFACE FINISH
9. ALL DIMENSIONS AND TOLERANCES ARE TO BE INTERPRETED ACCORDING TO ASME Y14.

intertek
Total Quality. Assured.

Report #: M4644.01
Date: 7/22/2021
Verified by: *[Signature]*

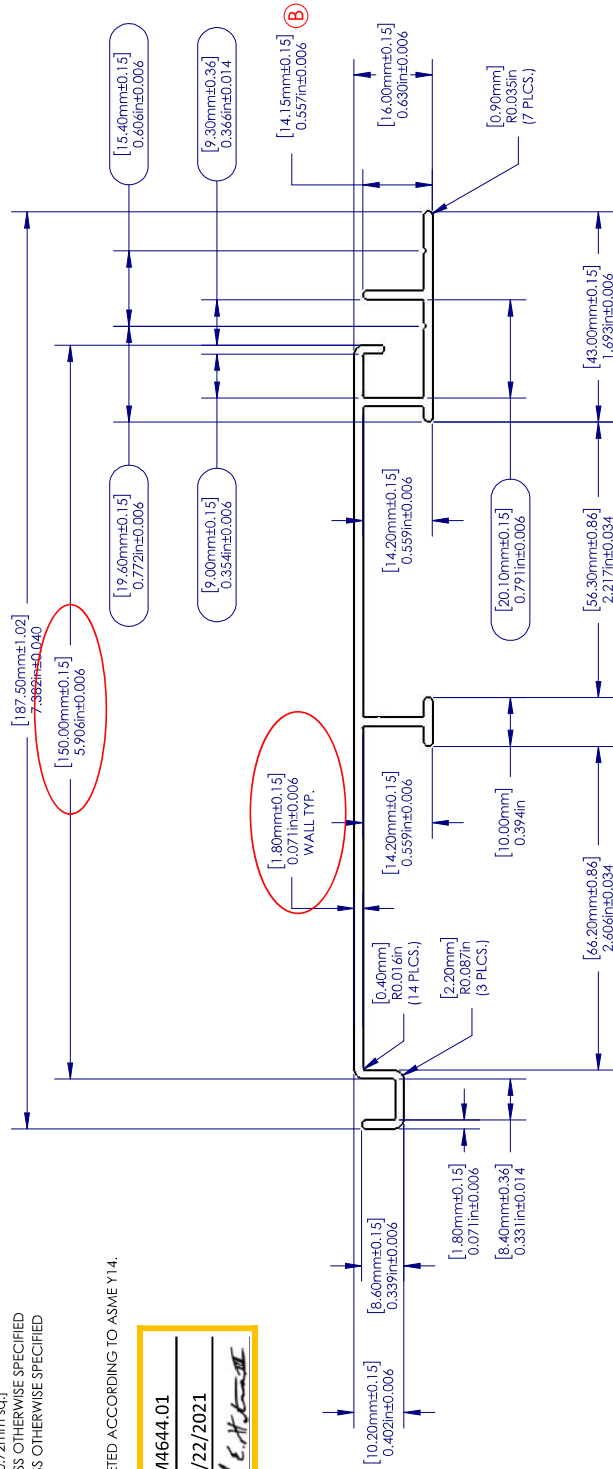

--- EXPOSED SURFACE

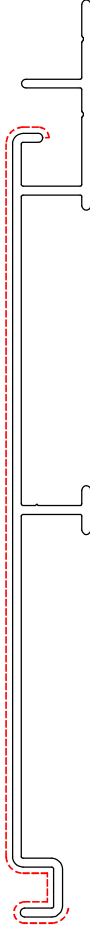

EXTRUSION PROFILE SCALE 1:1

	kg/m	lbs./ft.
WEIGHT/LENGTH	1.294	0.867
AREA	479.37 sq. mm	0.7430 sq. in.
TOTAL PERIMETER	532.55 mm	20.9665 in.
OUTSIDE PERIMETER	532.55 mm	20.9665 in.
EXPOSED PERIMETER	190.38 mm	7.4952 in.

4

3

2

1

A

A

LEVANTÉ
ALUMINUM ARCHITECTURAL COMPONENTS

NAME: EASS DATE: 06/01/20

DRAWN: [] CHECKED: []

ENG APPR: [] MFG APPR: [] Q.A.: []

TITLE: 150mm - 6" Interlocking Board

SIZE: PART NO. LDC619 REV D

SCALE: 1:1 WEIGHT: 16.677 SHEET 2 OF 3

UNLESS OTHERWISE SPECIFIED: DIMENSIONS ARE IN INCHES (MM) TOLERANCES: MILLIMETERS: X = ±0.1, Y = ±0.15, Z = ±0.15, XX = ±0.05, YY = ±0.05, ZZ = ±0.05

ANGLES: A = ±1°

FRACTIONS: X/A = ±1/64

INTERPRET GEOMETRIC TOLERANCING PER: []

MATERIAL: 6063-T5

FINISH: Powder Coat

APPLICATION: NEXT ASY USED ON DO NOT SCALE DRAWING

COMMENTS: PROPRIETARY AND CONFIDENTIAL THE INFORMATION CONTAINED IN THIS DRAWING IS THE SOLE PROPERTY OF LEVANTÉ. NO PART OF THIS DRAWING IS TO BE REPRODUCED OR TRANSMITTED IN ANY FORM OR BY ANY MEANS, WITHOUT THE WRITTEN PERMISSION OF LEVANTÉ. ILC IS PROHIBITED.

B

B



Total Quality. Assured.

130 Derry Court
York, Pennsylvania 17406

Telephone: 717-764-7700
Facsimile: 717-764-4129
www.intertek.com/building

TEST REPORT FOR HALLMARK BUILDING SUPPLIES, INC.

Report No.: M4644.01-109-44

Date: 08/12/21

SECTION 2

REVISION LOG

REVISION #	DATE	PAGES	REVISION
0	08/12/21	N/A	Original Report Issue

HALLMARK BUILDING SUPPLIES, INC. TEST REPORT

SCOPE OF WORK

ASTM E330/E330M, PROCEDURE B TESTING ON LEVANTE 6" INTERLOCKING BOARD,
CLADDING OVER 2" RIGID FOAM

REPORT NUMBER

N9173.01-109-40

TEST DATE

08/15/22

ISSUE DATE

09/22/22

RECORD RETENTION END DATE

08/15/26

PAGES

18

DOCUMENT CONTROL NUMBER

RT-R-AMER-Test-2805 (10/11/21)

© 2017 INTERTEK

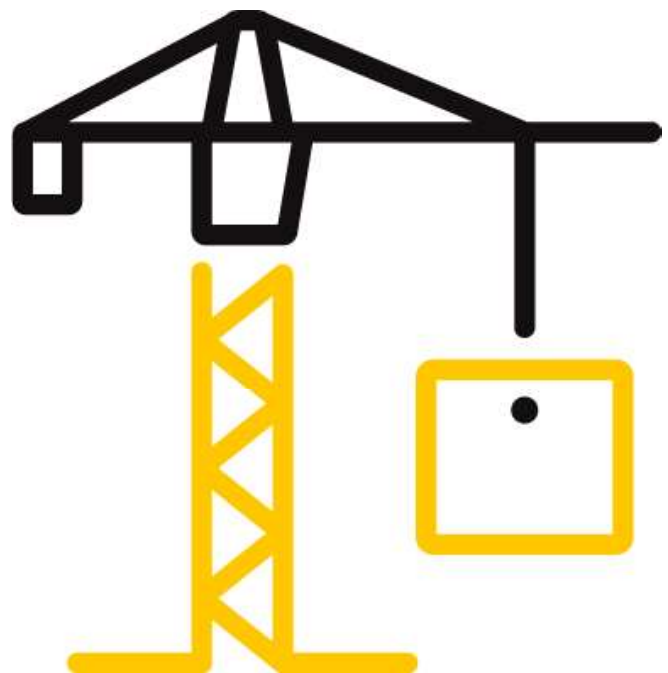

TEST REPORT FOR HALLMARK BUILDING SUPPLIES, INC.

Report No.: N9173.01-109-40

Date: 09/22/22

REPORT ISSUED TO

HALLMARK BUILDING SUPPLIES, INC.

901 Northview Road, Suite 100

Waukesha, Wisconsin 53188

SECTION 1

SCOPE

Architectural Testing, Inc. (an Intertek company) dba Intertek Building & Construction (B&C) was contracted by Hallmark Building Supplies, Inc. to perform testing in accordance with ASTM E330/E330M, Procedure B on their Levante 6" Interlocking Board, cladding over 2" rigid foam. Results obtained are tested values and were secured by using the designated test method(s). Testing was conducted at the Intertek B&C test facility in York, Pennsylvania.

SECTION 2

SUMMARY OF TEST RESULTS

TITLE	TEST SPECIMEN #1
Negative Design Pressure	-11172 Pa (-233.33 psf)
Uniform Load Structural Test Pressure	-16758 Pa (-350.00 psf)

TITLE	TEST SPECIMEN #2
Negative Design Pressure	-9895 Pa (-206.67 psf)
Uniform Load Structural Test Pressure	-14843 Pa (-310.00 psf)

TITLE	TEST SPECIMEN #3
Negative Design Pressure	-11172 Pa (-233.33 psf)
Uniform Load Structural Test Pressure	-16758 Pa (-350.00 psf)

For INTERTEK B&C:

COMPLETED BY:	Jason R. Zeller	REVIEWED BY:	Ken R. Stough
TITLE:	Technician – Product Testing	TITLE:	Project Manager – Product Testing
SIGNATURE:	 <small>Digitally Signed by: Jason Zeller</small>	SIGNATURE:	 <small>Digitally Signed by: Ken Stough</small>
DATE:	09/22/22	DATE:	09/22/22

JRZ:nls

This report is for the exclusive use of Intertek's Client and is provided pursuant to the agreement between Intertek and its Client. Intertek's responsibility and liability are limited to the terms and conditions of the agreement. Intertek assumes no liability to any party, other than to the Client in accordance with the agreement, for any loss, expense or damage occasioned by the use of this report. Only the Client is authorized to permit copying or distribution of this report and then only in its entirety. Any use of the Intertek name or one of its marks for the sale or advertisement of the tested material, product or service must first be approved in writing by Intertek. The observations and test results in this report are relevant only to the sample(s) tested. This report by itself does not imply that the material, product, or service is or has ever been under an Intertek certification program.

TEST REPORT FOR HALLMARK BUILDING SUPPLIES, INC.

Report No.: N9173.01-109-40

Date: 09/22/22

SECTION 3

TEST METHOD(S)

The specimens were evaluated in accordance with the following:

ASTM E330/E330M-14(2021), *Standard Test Method for Structural Performance of Exterior Windows, Doors, Skylights and Curtain Walls by Uniform Static Air Pressure Difference*

SECTION 4

MATERIAL SOURCE/INSTALLATION

Test specimens were provided by the client. Representative samples of the test specimens will be retained by Intertek B&C for a minimum of four years from the test completion date.

Installation of the tested product was performed by Intertek B&C.

SECTION 5

EQUIPMENT

Tape Measure Verification: 63788

Weather Station: 63316

Control Panel: 005406

Linear Transducers: 62187, 62189, 64460, 64461

SECTION 6

LIST OF OFFICIAL OBSERVERS

NAME	COMPANY
Ken R. Stough	Intertek B&C
Jason R. Zeller	Intertek B&C

TEST REPORT FOR HALLMARK BUILDING SUPPLIES, INC.

Report No.: N9173.01-109-40

Date: 09/22/22

SECTION 7

TEST SPECIMEN DESCRIPTION

Product Type: Cladding over 2" Rigid Foam

Series/Model: Levante 6" Interlocking Board

Test Specimen #1 - #3:

OVERALL AREA:	WIDTH		HEIGHT	
	millimeters	inches	millimeters	inches
2.9 m ² (31.1 ft ²)				
Overall size	1219	48	2372	93-3/8
Panel size (15)	1219	48	187	7-3/8

Test Wall Construction:

The specimens were installed onto a test buck measuring 51" wide by 99" high constructed of #2 Spruce-Pine-Fir nominal 2x6 lumber and wrapped with #2 Spruce-Pine-Fir nominal 2x10 lumber. Two studs were spaced 16" on center (three spans) and were attached to the top and bottom lumber with 3" long flat head screws. Each stud was reinforced with 2" by 2" angle irons secured with four #10 x 1-1/2" pan head screws. A sheet of nominal 15/32" thick plywood, with five 4" diameter holes to allow pressure to transfer to the cladding, was secured to the studs with #8 x 1-5/8" flat head screws. Silicone was utilized on the backside of the test panel to seal the perimeter. A 2 mil thick plastic film was loosely draped over the interior of the cladding to enable attainment of pressure.

Panel Description:

Each 6" interlocking board was constructed of 0.071" thick extruded aluminum and measured 48" wide by 7-3/8" high. Each course utilized a male interlock at the top and female interlock at the bottom and a 0.640" fastener leg below the female interlock.

Test Specimen Installation:

A 48" wide by 96" high by 2" thick sheet of rigid insulation foam was installed to the test buck using #8 x 3" self-drilling flat head screws with 2" plastic washers, spaced 16" on center around the perimeter and field studs. A 48" long by 2-5/8" tall, extruded aluminum starter trim was installed horizontally at the top of the test buck and fastened using 5/16" x 4" rugged structural screws located 3/4" from each end and spaced 16" on center, through the starter trim, 2" foam, and plywood, into the studs. A 6" interlocking board was interlocked to the starter trim and fastened using 5/16" x 4" rugged structural screws located 3/4" from each end and spaced 16" on center, through the fastener leg, 2" foam, and plywood, into the test studs. A total of 15 courses were installed.

TEST REPORT FOR HALLMARK BUILDING SUPPLIES, INC.

Report No.: N9173.01-109-40

Date: 09/22/22

SECTION 8
TEST RESULTS

The temperature range during testing was 26°-28°C (78°-82°F). The results are tabulated as follows:

Test Specimen #1:

TITLE OF TEST	RESULTS	NOTE
Uniform Load Deflection, per ASTM E330 Deflections taken between fasteners -1915 Pa (-40.00 psf)	0.3 mm (0.01")	1, 2
Uniform Load Structural, per ASTM E330 Permanent set taken between fasteners -1915 Pa (-40.00 psf)	<0.3 mm (<0.01")	1, 2
Uniform Load Deflection, per ASTM E330 Deflections taken between fasteners -10534 Pa (-220.00 psf)	2.0 mm (0.08")	1, 2
Uniform Load Structural, per ASTM E330 Permanent set taken between fasteners -10534 Pa (-220.00 psf)	0.3 mm (0.01")	1, 2
Uniform Load Deflection, per ASTM E330 Deflections taken between fasteners -13406 Pa (-280.00 psf)	2.5 mm (0.10")	1, 2
Uniform Load Structural, per ASTM E330 Permanent set taken between fasteners -13406 Pa (-280.00 psf)	0.5 mm (0.02")	1, 2
Uniform Load Deflection, per ASTM E330 Deflections taken between fasteners -16758 Pa (-350.00 psf)	3.3 mm (0.13")	1, 2
Uniform Load Structural, per ASTM E330 Permanent set taken between fasteners -16758 Pa (-350.00 psf)	0.5 mm (0.02")	1, 2

TEST REPORT FOR HALLMARK BUILDING SUPPLIES, INC.

Report No.: N9173.01-109-40

Date: 09/22/22

Test Specimen #2:

TITLE OF TEST	RESULTS	NOTE
Uniform Load Deflection, per ASTM E330 Deflections taken between fasteners -1915 Pa (-40.00 psf)	0.3 mm (0.01")	1, 2
Uniform Load Structural, per ASTM E330 Permanent set taken between fasteners -1915 Pa (-40.00 psf)	<0.3 mm (<0.01")	1, 2
Uniform Load Deflection, per ASTM E330 Deflections taken between fasteners -10534 Pa (-220.00 psf)	1.8 mm (0.07")	1, 2
Uniform Load Structural, per ASTM E330 Permanent set taken between fasteners -10534 Pa (-220.00 psf)	0.3 mm (0.01")	1, 2
Uniform Load Deflection, per ASTM E330 Deflections taken between fasteners -13406 Pa (-280.00 psf)	2.3 mm (0.09")	1, 2
Uniform Load Structural, per ASTM E330 Permanent set taken between fasteners -13406 Pa (-280.00 psf)	0.5 mm (0.02")	1, 2
Uniform Load Deflection, per ASTM E330 Deflections taken between fasteners -14843 Pa (-310.00 psf)	2.5 mm (0.10")	1, 2
Uniform Load Structural, per ASTM E330 Permanent set taken between fasteners -14843 Pa (-310.00 psf)	0.3 mm (0.01")	1, 2

TEST REPORT FOR HALLMARK BUILDING SUPPLIES, INC.

Report No.: N9173.01-109-40

Date: 09/22/22

Test Specimen #3:

TITLE OF TEST	RESULTS	NOTE
Uniform Load Deflection, per ASTM E330 Deflections taken between fasteners -1915 Pa (-40.00 psf)	0.3 mm (0.01")	1, 2
Uniform Load Structural, per ASTM E330 Permanent set taken between fasteners -1915 Pa (-40.00 psf)	<0.3 mm (<0.01")	1, 2
Uniform Load Deflection, per ASTM E330 Deflections taken between fasteners -10534 Pa (-220.00 psf)	2.0 mm (0.08")	1, 2
Uniform Load Structural, per ASTM E330 Permanent set taken between fasteners -10534 Pa (-220.00 psf)	0.5 mm (0.02")	1, 2
Uniform Load Deflection, per ASTM E330 Deflections taken between fasteners -13406 Pa (-280.00 psf)	2.8 mm (0.11")	1, 2
Uniform Load Structural, per ASTM E330 Permanent set taken between fasteners -13406 Pa (-280.00 psf)	0.5 mm (0.02")	1, 2
Uniform Load Deflection, per ASTM E330 Deflections taken between fasteners -16758 Pa (-350.00 psf)	3.3 mm (0.13")	1, 2
Uniform Load Structural, per ASTM E330 Permanent set taken between fasteners -16758 Pa (-350.00 psf)	0.5 mm (0.02")	1, 2

General Note: All testing was performed in accordance with the referenced standard(s).

Note 1: Loads were held for 10 seconds.

Note 2: Tape and film were used to seal against air leakage during structural testing. In our opinion, the tape and film did not influence the results of the test.

TEST REPORT FOR HALLMARK BUILDING SUPPLIES, INC.

Report No.: N9173.01-109-40

Date: 09/22/22

SECTION 9

CONCLUSION

This report does not constitute certification of this product nor an opinion or endorsement by this laboratory. Intertek B&C will service this report for the entire test record retention period. The test record retention period ends four years after the test date. Test records, such as detailed drawings, datasheets, representative samples of test specimens, or other pertinent project documentation, will be retained for the entire test record retention period.

Unless differently required, Intertek reports apply the "Simple Acceptance" rule, also called "Shared Risk approach," of ILAC-G8:09/2019, Guidelines on Decision Rules and Statements of Conformity.

TEST REPORT FOR HALLMARK BUILDING SUPPLIES, INC.

Report No.: N9173.01-109-40

Date: 09/22/22

SECTION 10 PHOTOGRAPHS

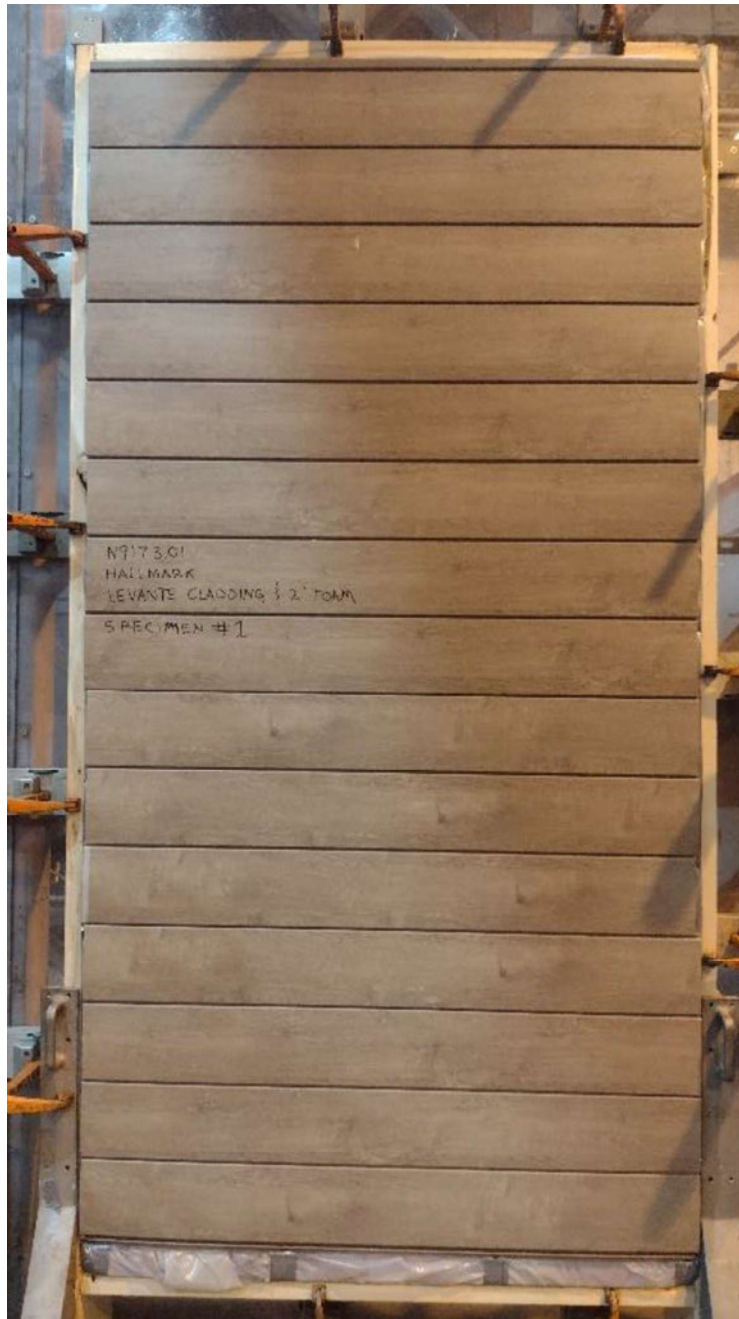

Photo No. 1
Specimen #1 Prior to Testing

TEST REPORT FOR HALLMARK BUILDING SUPPLIES, INC.

Report No.: N9173.01-109-40

Date: 09/22/22



Photo No. 2
Specimen #2 Prior to Testing

TEST REPORT FOR HALLMARK BUILDING SUPPLIES, INC.

Report No.: N9173.01-109-40

Date: 09/22/22



Photo No. 3
Specimen #3 Prior to Testing



Total Quality. Assured.

130 Derry Court
York, Pennsylvania 17406

Telephone: 717-764-7700
Facsimile: 717-764-4129
www.intertek.com/building

TEST REPORT FOR HALLMARK BUILDING SUPPLIES, INC.

Report No.: N9173.01-109-40

Date: 09/22/22

SECTION 11 DRAWINGS

The test specimen drawings have been reviewed by Intertek B&C and are representative of the test specimen(s) reported herein. Test specimen construction was verified by Intertek B&C per the drawings included in this report. Any deviations are documented herein or on the drawings.

8 7 6 5 4 3 2 1



LEVANTÉ LLC
 901 NORTHVIEW ROAD
 SUITE 100
 WAUKESHA, WISCONSIN 53188

Project Name:
 Used on assembly:

Part Name:
 1.50mm - 6" INTERLOCKING BOARD

Part No.:
 LDC619

Drawing Number:
 AL-13689-D

REVISIONS

REV.	DESCRIPTION	DATE	APPROVED
B	DIMENSION INDICATED BY A RED LETTER 'B' HAS BEEN MODIFIED FROM 0.587" [14.90mm] TO 0.557" [14.15mm]. SLOT CUTS HAVE BEEN ADDED ALONG PROFILE'S LENGTH.	4/17/2020	EASS
C	LOCATION OF SLOT HOLES HAVE BEEN MODIFIED TO BE ALONG V-GROOVE SECTION. NUMBER OF SLOT HOLE ROWS WAS DECREASED FROM TWO ROWS TO ONE ROW.	5/14/2020	EASS
D	SLOT WIDTH HAS BEEN DECREASED FROM 0.197" [5.00mm] TO 0.1695" [4.30mm]; SLOT LENGTH HAS BEEN MODIFIED FROM 0.591" [15.00mm] TO 0.661" [16.80mm]; TYPICAL SPACING BETWEEN EACH SLOT HAS BEEN MODIFIED FROM 0.986" [25.05mm] FROM SLOTS EDGES TO 4.000" [101.60mm] FROM SLOT CENTERS; FIRST AND LAST SLOT STARTS/TENDS 1.000" [25.40mm] FROM EDGES.	6/1/2020	EASS

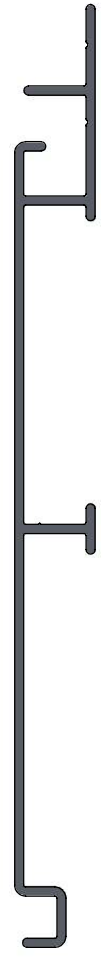

EXTRUSION PROFILE
 SCALE 1:1

F E D C B A

8 7 6 5 4 3 2 1

4

3

2

1

NOTES:

1. EXTRUSION SHALL BE STRAIGHT WITHIN 1.1mm PER 1M [0.015'/FOOT]
2. EXTRUSION TWIST 1.0DEG PER 1M [1.0DEG/FOOT]
3. EXTRUSION CROSS SECTIONAL AREA IS 0.7451 sq.in. [480.72mm sq.]
4. ALL RADII & FILLET RADIUS TO BE R0.016" [0.40mm] UNLESS OTHERWISE SPECIFIED
5. SECTIONAL MATERIAL THICKNESS 0.071" [1.80mm] UNLESS OTHERWISE SPECIFIED
6. CRITICAL DIMENSIONS ARE SHOWN WITHIN \varnothing
7. REFERENCE DIMENSIONS ARE SHOWN WITHIN ()
8. ALL DIMENSIONS INCLUDE SURFACE FINISH
9. ALL DIMENSIONS AND TOLERANCES ARE TO BE INTERPRETED ACCORDING TO ASME Y14.

intertek
Total Quality Assurance

Report #: N9173.01
Date: 08/16/22
Verified by: *RAZ*

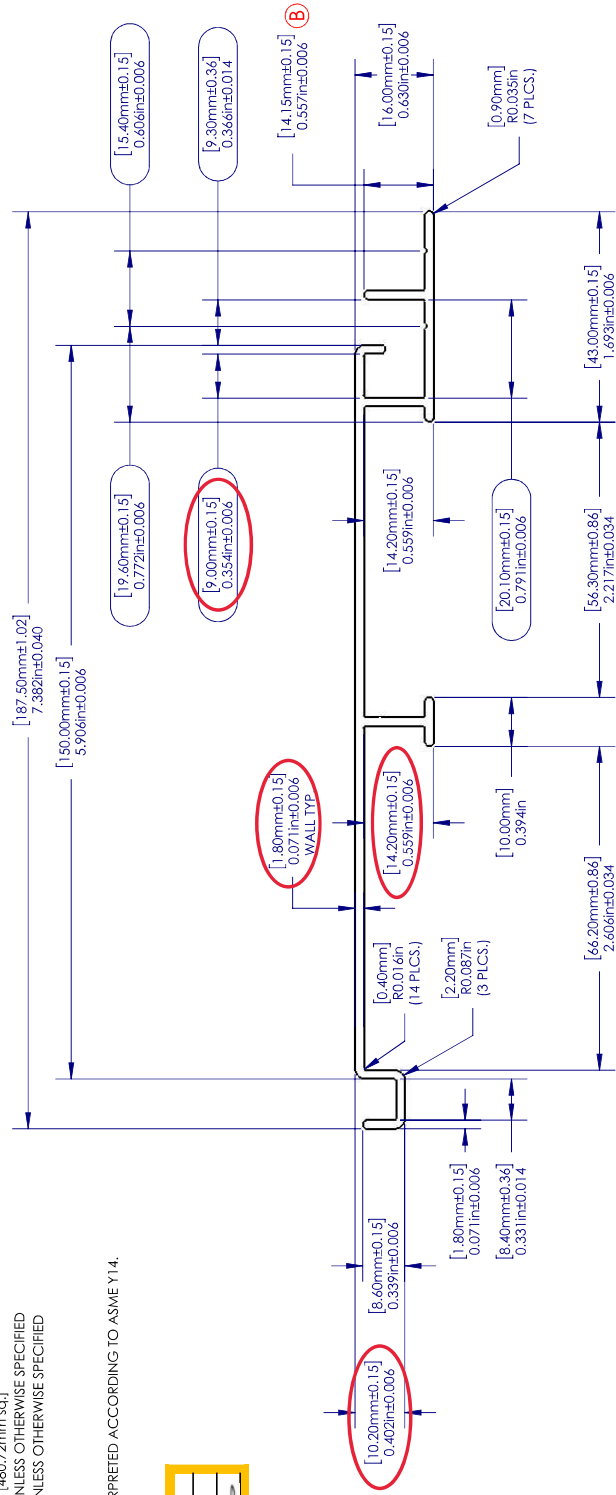

--- EXPOSED SURFACE

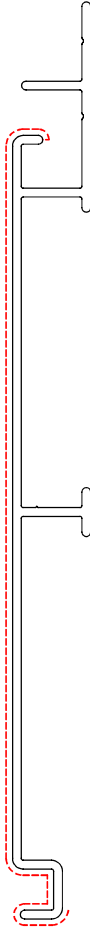

EXTRUSION PROFILE
SCALE 1:1

	kg/m	lbs./ft.
WEIGHT/LENGTH	1.294	0.867
AREA	479.37 sq. mm	0.7430 sq. in.
TOTAL PERIMETER	532.55 mm	20.9665 in.
OUTSIDE PERIMETER	532.55 mm	20.9665 in.
EXPOSED PERIMETER	190.38 mm	7.4952 in.

4

3

2

1

A



150mm - 6"
Interlocking Board

SIZE PART NO. LDC619
REV D
SCALE: 1:1 WEIGHT: 16.677 SHEET 2 OF 3

UNLESS OTHERWISE SPECIFIED:	NAME	DATE
DIMENSIONS ARE IN INCHES (MM) <td>EASS</td> <td>06/01/20</td>	EASS	06/01/20
TOLERANCES:	DRAWN	CHECKED
MILLIMETERS	ENG APPR.	MFG APPR.
X ± 0.1	Q.A.	COMMENTS:
X/2 ± 0.1		
X/4 ± 0.1		
X/8 ± 0.1		
X/16 ± 0.1		
X/32 ± 0.1		
ANGLES		
≤ ± 1°		
FRACTIONS		
X/8 ± 1/64		
INTERPRET GEOMETRIC TOLERANCING PER:		
MATERIAL	6063-T5	
FINISH	Powder Coat	
USED ON		
APPLICATION		
DO NOT SCALE DRAWING		

PROPRIETARY AND CONFIDENTIAL
THE INFORMATION CONTAINED IN THIS DRAWING IS THE SOLE PROPERTY OF LEVANTÉ. NO REPRODUCTION IN PART OR AS A WHOLE WITHOUT THE WRITTEN PERMISSION OF LEVANTÉ LLC IS PROHIBITED.

A

4 3 2 1

NOTES:

1. EXTRUSION SHALL BE STRAIGHT WITHIN 1.1mm PER 1M [0.015"/FOOT]
2. EXTRUSION TWIST 1.0DEG PER 1M [1.0DEG/FOOT]
3. EXTRUSION CROSS SECTIONAL AREA IS 0.7451 sq.in. [480.72mm sq]
4. ALL RADII BULLET RADIUS TO BE R0.016" [0.40mm] UNLESS OTHERWISE SPECIFIED
5. SECTIONAL MATERIAL THICKNESS 0.071" [1.80mm] UNLESS OTHERWISE SPECIFIED
6. CRITICAL DIMENSIONS ARE SHOWN WITHIN \varnothing
7. REFERENCE DIMENSIONS ARE SHOWN WITHIN ()
8. ALL DIMENSIONS INCLUDE SURFACE FINISH
9. ALL DIMENSIONS AND TOLERANCES ARE TO BE INTERPRETED ACCORDING TO ASME Y14.

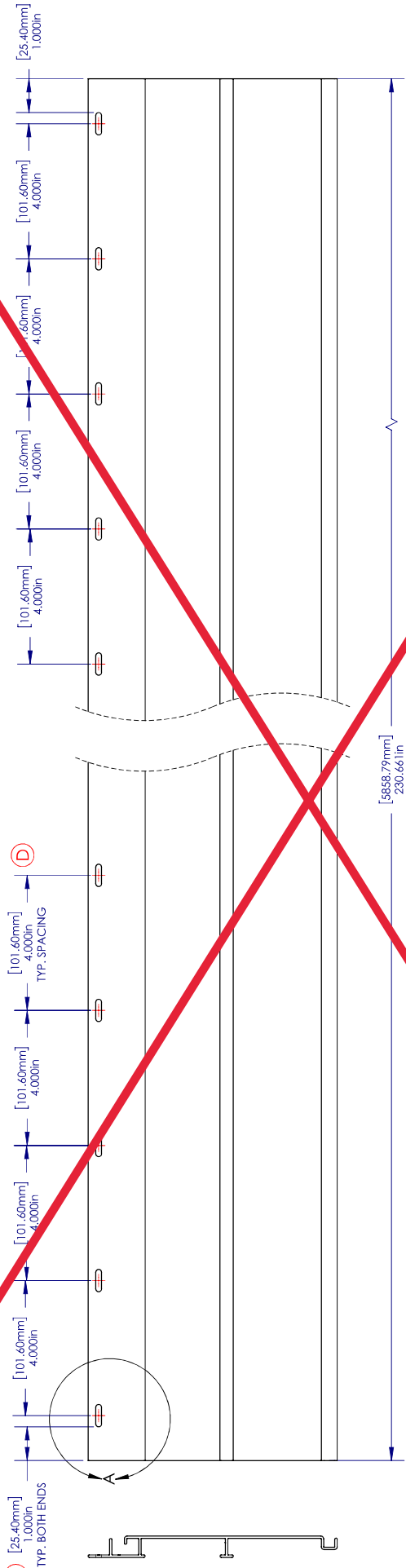

		150mm 6" Interlocking Board Fabrication Drawing	
NAME	EASS	DRAWN	06/01/2018
CHECKED		ENG APPR.	
MFG APPR.		Q.A.	
COMMENTS:			
MATERIAL	6063-T5	FINISH	Powder Coat
APPLICATION	DO NOT SCALE DRAWING	USED ON	
NEXT ASSY		SIZE PART NO.	B LDC619
REV	D	SCALE:	1:3 WEIGHT: 16.677 SHEET 3 OF 3

DETAIL A
SCALE 2:3

PROPRIETARY AND CONFIDENTIAL
 THE INFORMATION CONTAINED IN THIS
 DRAWING IS THE SOLE PROPERTY OF
 LEVANTÉ ARCHITECTURAL COMPONENTS
 IN PART OR AS A WHOLE. NO REPRODUCTION
 WITHOUT THE WRITTEN PERMISSION OF
 LEVANTÉ ARCHITECTURAL COMPONENTS.
 ALL RIGHTS RESERVED.

4 3 2 1

A

B

A

B

8 7 6 5 4 3 2 1



LEVANTÉ[®]
ALUMINUM ARCHITECTURAL COMPONENTS

LEVANTÉ, LLC
901 NORTHVIEW ROAD
SUITE 100
WAUKESHA, WISCONSIN 53188

Project Name:

Used on assembly:

Part Name:
STARTER TRIM

Part No.:
LDS319

Drawing Number:
AL-13692-A

REVISIONS

REV.	DESCRIPTION	DATE	APPROVED

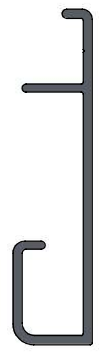

EXTRUSION PROFILE
SCALE 1:1

8 7 6 5 4 3 2 1

F

E

D

C

B

A

4

3

2

1

NOTES:

1. EXTRUSION SHALL BE STRAIGHT WITHIN 1.1mm PER 1M [0.015'/FOOT]
2. EXTRUSION TWIST 1.0DEG PER 1M [1.0DEG/FOOT]
3. EXTRUSION CROSS SECTIONAL AREA IS 0.3225 sq.in. [208.72mm sq.]
4. ALL RADI & FILLET RADIUS TO BE R0.031" [0.79mm] UNLESS OTHERWISE SPECIFIED
5. SECTIONAL MATERIAL THICKNESS 0.071"±0.006" [1.80mm±0.15mm] UNLESS OTHERWISE SPECIFIED
6. CRITICAL DIMENSIONS ARE SHOWN WITHIN ()
7. REFERENCE DIMENSIONS ARE SHOWN WITHIN []
8. ALL DIMENSIONS ARE FINISHED PART DIMENSIONS
9. ALL DIMENSIONS AND TOLERANCES ARE TO BE INTERPRETED ACCORDING TO ASME Y14.
10. SURFACE FINISH AS PER CUSTOMER'S PURCHASE ORDER

intertek
Total Quality Assurance

Report #: N9173.01
Date: 08/16/22
Verified by: *[Signature]*

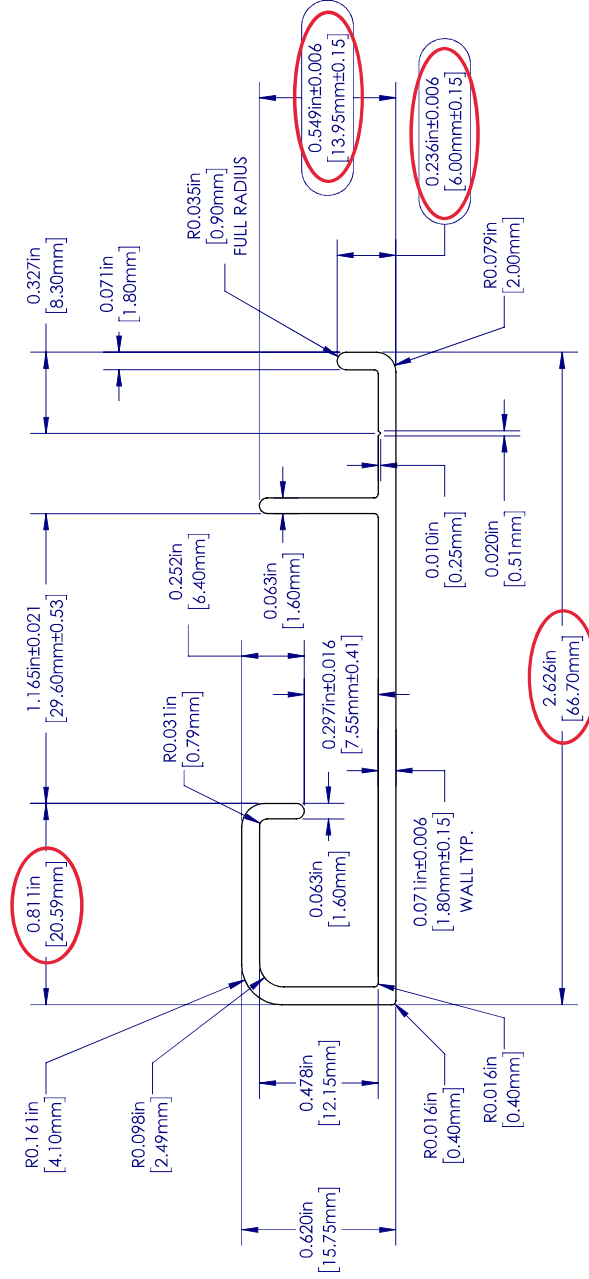

--- EXPOSED SURFACE



EXTRUSION PROFILE
SCALE 1:1

	kg/m	lbs./ft.
WEIGHT/LENGTH	0.570	0.383
AREA	208.72 sq. mm	0.3225 sq. in.
TOTAL PERIMETER	236.69 mm	9.3187 in.
OUTSIDE PERIMETER	236.69 mm	9.3187 in.
EXPOSED PERIMETER	41.90 mm	1.6497 in.

4

3

2

1

B

A

A

B



TITLE:

Starter Trim

UNLESS OTHERWISE SPECIFIED: DIMENSIONS ARE IN INCHES (MM) TOLERANCES: MILLIMETERS X = ± 0.1 Y = ± 0.20 Z = ± 0.10 XX = ± 0.25 XXX = ± 0.25	NAME EASS	DATE 7/17/19
DRAWN	CHECKED	ENG APPR.
MFG APPR.	Q.A.	COMMENTS:
MATERIAL 6063-T5		
FINISH		
DO NOT SCALE DRAWING	APPLICATION	USED ON
NEXT ASSY	USED ON	

PROPRIETARY AND CONFIDENTIAL
THE INFORMATION CONTAINED IN THIS
DRAWING IS THE SOLE PROPERTY OF
LEVANTÉ ARCHITECTURAL COMPONENTS
IN PART OR AS A WHOLE. REPRODUCTION
WITHOUT THE WRITTEN PERMISSION OF
LEVANTÉ ILLC IS PROHIBITED.

SIZE	PART NO.	REV
B	LDS319	A
SCALE: 2:1	WEIGHT: 7.19	SHEET 2 OF 2



Total Quality. Assured.

130 Derry Court
York, Pennsylvania 17406

Telephone: 717-764-7700
Facsimile: 717-764-4129
www.intertek.com/building

TEST REPORT FOR HALLMARK BUILDING SUPPLIES, INC.

Report No.: N9173.01-109-40

Date: 09/22/22

SECTION 12

REVISION LOG

REVISION #	DATE	PAGES	REVISION
0	09/22/22	N/A	Original Report Issue



Levanté® Cleaning and Maintenance Guide

Levanté® requires an initial clean after installation and periodic cleaning and maintenance for the lifecycle of the product. Levanté's finish possesses exceptional resistance to corrosion, discoloration and wear, and its natural beauty can be marred by harsh chemicals, rough conditions, or neglect. Marks resulting from mistreatment may be permanent, however such conditions normally affect only the surface finish and do not reduce the service life of the product.

Initial Cleaning after Installation

Clean Levanté® products once material has been installed to ensure the removal of construction debris such as metal shavings, concrete, plaster, and paint before they dry. Failure to remove construction debris at this stage may cause attachment onto surface of product and may require the use of abrasive cleaning materials and techniques which has the potential to damage the finish surface.

Maintenance Cleanings

Levanté® products should be regularly washed using warm water and non-abrasive, pH neutral detergent solutions. Small quantity of detergent (tablespoon) should be mixed into a bucket (3-4 gallons) of warm water. Surfaces need to be rinsed with warm water before any cleaning agents are applied. Clean in small sections to avoid drying before all cleaning agents can be rinsed. A soft cloth, sponge, or soft bristle brush can be used to clean residual debris on surface.

Recommended Maintenance Cleaning Schedules

Frequency of cleaning depends on several factors: environment surrounding the building, atmospheric pollution, winds and air borne debris (i.e. sand, salt water, dirt), protection from surrounding buildings or natural features, and geographical location. Below is a list of typical maintenance cleaning schedules:

- Non-aggressive Environments: Check and Clean every 12 months
- Tropical Environments: Check and Clean every 9 months
- Chlorinated Swimming and Leisure Pools: Check and Clean every 6 months
- Marine Environments: Check and Clean every 3 months
- Heavy Industrial Environments: Check and Clean every 3 months
- Aggressive/Hazardous Environments: Check and Clean every 1 month

Cleaning should be done on a mild day and never in direct sunlight.

Soil Level on Levanté® product will determine how material should be cleaned

Light Surface Soil

Always start the cleaning process from the top of the area working down or from the building working away. Surfaces need to be rinsed with warm water before any cleaning agents are applied. Use moderate water pressure to dislodge soil from surface. If soil is still visible after drying, the use of a mild cleaning agent and soft brush or cloth will be necessary. Clean surface with light uniform pressure in both a horizontal and vertical motion. Always rinse the area with warm water after a cleaning agent has been installed, making sure to remove all chemical residue.

Medium Surface Soil

If surface soil is still visible after Light Surface Cleaning, the use of a cleaning pad can assist with removal of debris. Hand scrub the surface using a wet cleaning pad with the woodgrain of the finish. After scrubbing the surface, always rinse the area with warm water to make sure to remove all chemical residue.

Use of power cleaning tools may be necessary for removal of medium to heavy surface soil. While using a power cleaning tool, the surface being cleaned must be constantly wet with clean water and/or mild detergent to provide lubrication and allow dirt to wash away. Overlap passes and clean in two directions to maximize cleaning. After area has been power cleaned, rinse area with clean warm water and scrub with a soft plastic bristle brush to remove cleaning residue. Lastly, rinse scrubbed surface with clean warm water.

Always test power cleaning and cleaning agents on a small, non-visible area initially to verify no color change or damage will occur.

Heavy Surface Soil

If surface soil is still visible after Medium Surface cleaning, the use of stronger detergents or solvents may be required. Some detergents and solvents may have an adverse effect on Levanté®'s surface finish so care should be taken before using this method. Always consult the Manufacturer and test solvents on a small, non-visible area.

Always follow Cleaning Agent's Manufacturer recommendations and proper concentrations/dilutions.

After area has been cleaned, rinse area with clean warm water and scrub with a soft plastic bristle brush to remove cleaning residue. Lastly, rinse scrubbed surface with clean warm water.

Warning!

Under no circumstances use strong solvents such as thinners or solutions containing Chlorinated Hydrocarbons, Esters, or Ketones. Never use aggressive alkaline or acid cleaners on finishes or cleaning agents containing Tri-sodium Phosphate, Phosphoric Acid, Hydrochloric Acid, Hydrofluoric Acid, Fluorides, or similar compounds. Cutting compounds and abrasive cleaners should never be used.

Never use excessive abrasive rubbing to remove stains. These procedures may produce an undesired change in appearance and finish.

Avoid using white spirits to assist with stubborn stains.

Avoid overspray or run-off of cleaner onto other building components. When cleaning other building components be cautious of cleaner running onto Levanté® products.

Never mix cleaning agents together. Some mixtures can be dangerous. Always rinse building components thoroughly after cleaning agents have been installed.

Some cleaning agents may be harmful to the environment. Always check the surroundings and cleaning agent's label to ensure compatibility.



Levanté® Product Warranty

Subject to the terms and conditions of this Warranty, Levanté®, LLC expressly warrants its products are free from manufacturing defects in material and workmanship if installed in accordance with our specifications, property maintained, and used for their intended purpose. For the purposes of this Warranty, the intended purpose of the Levanté® products is defined as residential and commercial cladding, residential and commercial fencing, privacy screens, and mechanical screens, residential and commercial soffits and ceilings, and residential decking and piers.

Material Warranty

1. **Buckling:** Levanté®, LLC hereby warrants that the product will be free of any buckling not associated with the substrate and/or structure to which the product is attached. For purposes of this warranty, buckling shall be defined as warping of the product exceeding 1/4" inch out of plane per linear foot.
2. **Rust and Corrosion:** When installed in accordance with Levanté®, LLC's installation specifications and properly maintained, Levanté®, LLC warrants that the product will be free of rusting and corrosion.
3. **Effect of Defect:** If a defect in material or workmanship occurs during the Warranty period, Levanté®, LLC will, at Levanté®, LLC's sole option, repair or replace the defective portion(s) of the product. If it is not possible to repair or replace the product, we will refund your original material purchase price. In no case will Levanté®, LLC be responsible for labor charges.
4. **Excluded Events:** This Warranty does not extend to, and will not cover, damages caused by or arising out of:
 - a. Shipping, handling or processing;
 - b. Installation;
 - c. Use of the products beyond normal use and service conditions, including use for purposes other than the intended use of the products;
 - d. Alteration and modifications of the products;
 - e. Insects or animals;
 - f. Structural defects in the structure on which the product is installed;
 - g. Movement, distortion, collapse or settling of the ground upon which the products, or the structure on which the product is installed;
 - h. Sound arising from, but not limited to, weather, expansion, contraction, flexing or vibration;
 - i. Improper handling or storage;
 - j. Acts of vandalism;
 - k. Abuse or neglect of the product;
 - l. Exposure to corrosive or aggressive atmospheres, including but not limited to chemical fumes, salt, standing water, and other corrosive elements;
 - m. Excessive heat, including damage caused by high heat sources such as grills and firepits;
 - n. Exposure to salt-water or salt air in marine or coastal areas;
 - o. Fire, flood, earthquakes, war, lightning, hail and acts of God; and
 - p. Ordinary wear and tear.

Finish (Wood-grain and Solid)

1. **Checking, Chalking:** During the warranty period there will be no visible checking, chalking, cracking, or fading per ASTM DG154/D2244 and D4214
2. **Scratch Resistance:** The material is scratch resistant per ASTM D4060

3. **Stain Resistance:** The product is considered stain resistant in accordance with AAMA 615 including bleach
4. **Color:** The color change due to sun exposure will be less than five CIE Lab AE units calculated in accordance with AAMA 2604. Color and pattern variation of components should be expected.
5. **Gloss Retention:** The surface will exhibit a gloss retention of at least 30% of the original. Gloss retention shall be measured on the exposed paint surface which has been cleaned of oil, grease, chalk, oxidized film, or other contaminants. (Panel stored in the dark at temperatures below 30 degrees C.)
6. **Maintenance Required:** Warranty is void if product is not cleaned annually in accordance with our Care and Maintenance Guide. Your maintenance records should indicate the date, time, specific products used along with the maintenance company's name and person providing the service.
7. **Effect of Defect:** If a defect in finish under this warranty has been deemed to have occurred, Levanté®, LLC will, at its sole option, either repair, refinish, or replace the product. All warranty work will be performed by a company or contractor selected by Levanté®, LLC, in its sole discretion. Color variance between repaired or refinished product and the original product shall not be indicative of a defect. If it is not possible to repair or replace the product, we will refund your original material price. In no case will Levanté®, LLC be responsible for labor charges.

Warranty Terms and Conditions

1. **Warranty:** This Warranty is given to either (1) the original purchaser of the products; or (2) the owner of the property at the time of installation of the product.
2. **Term:** The period of the Warranty is free of defects on finish for a period of 5 years for Solid Finish and 15 years for Decoral (Woodgrain) Finish; free of defects in materials for 25 years; free of defects in workmanship on balconies for 25 years from the date of delivery. It is agreed that tender of delivery of the product for the purposes of this warranty is made when the product is delivered to the jobsite regardless of when the product is installed.
3. **Non-transferrable:** This warranty is non-transferrable, without the express written consent of Levanté®, LLC, which may be withheld or conditioned in its sole discretion.
4. **Warranty Registration:** Levante product must be registered within 45 days of installation. Warranty Registration must be completed by following the directions on the Levante website: <https://levantealuminum.com/>. Warranty Registration form and supporting documentation must be submitted to attain Levante Warranty.
5. **Claims:** Any claims must be made within 30 days of discovery Claims must include proof of registration or original purchase receipt. Levanté®, LLC must be given a reasonable opportunity to inspect and verify the claim. Claims must be submitted on the Levante Website: <https://levantealuminum.com/>. Claim Form and supporting documentation must be submitted to process claim.
6. **Entire Agreement:** This Warranty represents the entire agreement between the Levanté®, LLC and the recipient of this non-transferrable Warranty. This Warranty supersedes any and all previous agreements or understanding, whether written or oral, in relation to the subject matter of this Warranty.
7. **No Further Liability:** The limited warranties contained in this Warranty represent the full and entire liability of Levanté®, LLC with respect to the products covered by Levanté®, LLC. Levanté®, LLC shall have no liability for any incidental or consequential damages, whether such damages are sought in contract, tort (including but not limited to negligence or strict liability) or otherwise. No person is authorized to make any representation or warranty related to the subject matter of this Warranty on behalf of Levanté®, LLC, and any such representation or warranty shall not be binding on Levanté®, LLC.
8. **No Warranty of Merchantability:** Levanté®, LLC makes no warranty of any kind, express or implied, any warranty or merchantability or fitness for a particular purpose.
9. **No Warranty of Workmanship:** Levanté®, LLC makes no warranty, express or implied, of the workmanship of any installer. Levanté®, LLC makes no warranty which would have the effect of imposing on Levanté®, LLC any liability for unsatisfactory performance caused by faulty workmanship upon installation.