



LEVANTÉ[®]
ARCHITECTURAL ALUMINUM

LEVANTÉ[®], LLC
901 NORTHVIEW ROAD
SUITE 100
WAUKESHA, WISCONSIN 53188

Project Name:

Part Name:

2 X 6 DECK BOARD

Used on assembly:

Part No.:

LBD26

Drawing Number:

HLM-AE-000901-XX-A

REVISIONS

REV.	DESCRIPTION	DATE	APPROVED
A	Initial Release	09/21/2023	Gautam Poddar



**EXTRUSION PROFILE
SCALE 1:1**

4

3

2

1

NOTES:

1. REFER TO CAD MODEL FOR UNSPECIFIED DIMENSIONS
2. EXTRUSION SHALL BE STRAIGHT WITHIN 1.1mm PER 1M [0.015"/FOOT]
3. EXTRUSION TWIST 1.0DEG PER 1M [1.0DEG/FOOT]
4. EXTRUSION CROSS SECTIONAL AREA IS 1,059.56 mm sq. [1.642 sq.in.]
5. ALL RADII & FILLET RADIUS TO BE 0.25 mm [0.010 in.] UNLESS OTHERWISE SPECIFIED
6. SECTIONAL MATERIAL THICKNESS 2.29 mm [0.090 in.] UNLESS OTHERWISE SPECIFIED
7. CRITICAL DIMENSIONS ARE SHOWN WITHIN
8. REFERENCE DIMENSIONS ARE SHOWN WITHIN ()
9. ALL DIMENSIONS INTERPRETED ACCORDING TO ASME Y14
10. ALL TOLERANCES ARE BASED ON ANSI H35.2

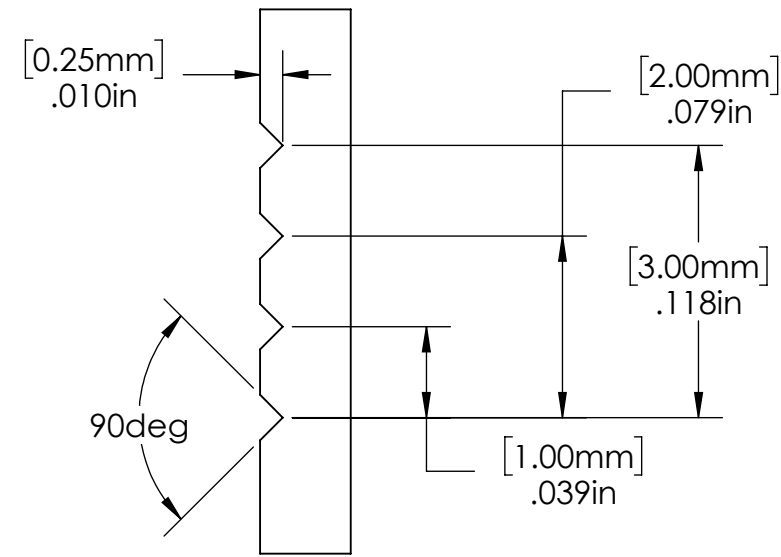

DETAIL ID MARKS
SCALE 12:1

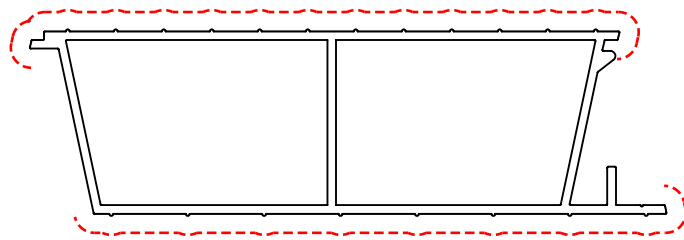

--- EXPOSED SURFACES
SCALE 1:2

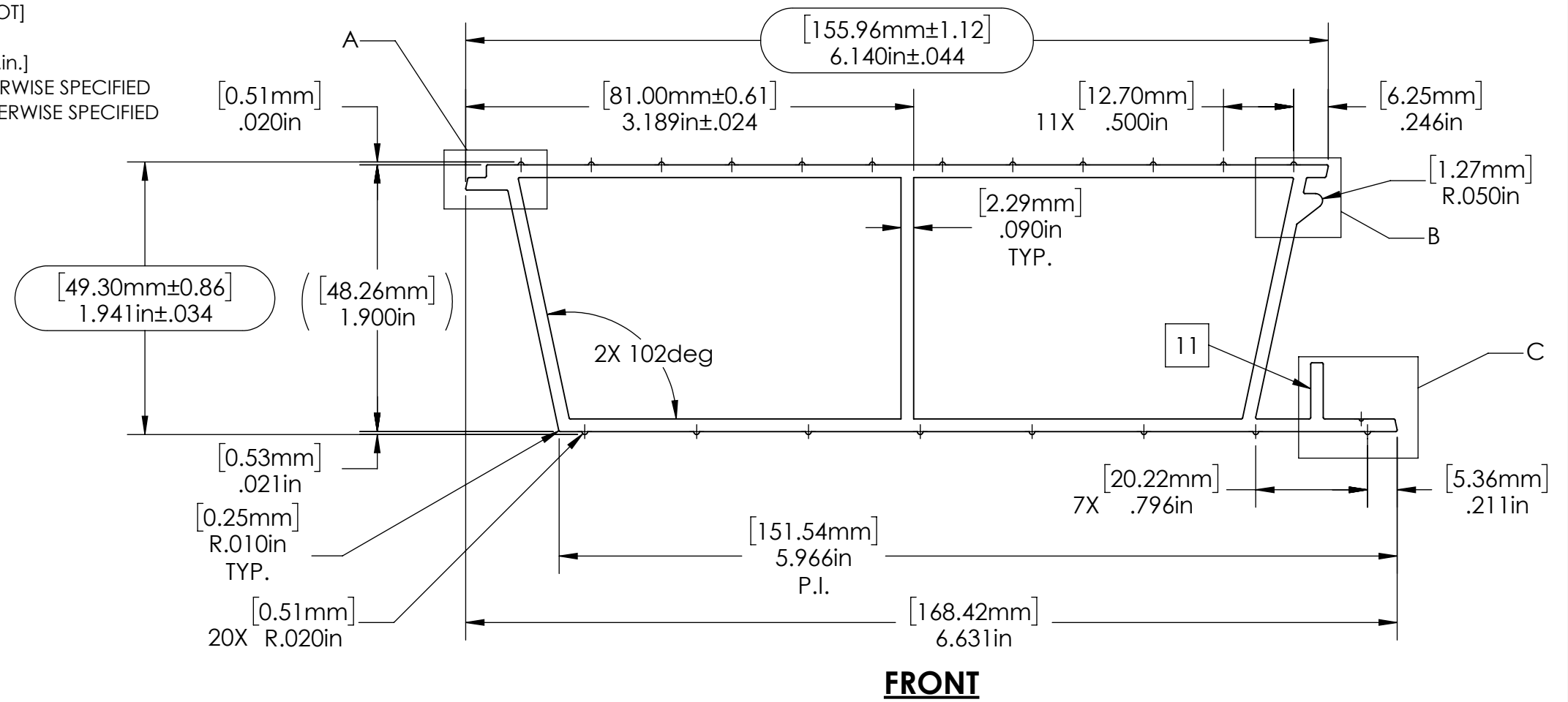

FRONT

WEIGHT/LENGTH	2.861	kg/m	1.922	lbs./ft.
AREA	1,059.56	sq. mm	1.642	sq. in.
TOTAL PERIMETER	911.62	mm	35.890	in.
OUTSIDE PERIMETER	478.02	mm	18.819	in.
EXPOSED PERIMETER	328.42	mm	12.930	in.

PROPRIETARY AND CONFIDENTIAL
 THE INFORMATION CONTAINED IN THIS DRAWING IS THE SOLE PROPERTY OF LEVANTÉ® LLC. ANY REPRODUCTION IN PART OR AS A WHOLE WITHOUT THE WRITTEN PERMISSION OF LEVANTÉ® LLC IS PROHIBITED.

UNLESS OTHERWISE SPECIFIED: DIMENSIONS ARE IN INCHES [MM] TOLERANCES:		NAME	DATE
MILLIMETERS	INCHES	GVP	9/8/2023
X = ±1	[.X = ±0.1]		
.X = ±.20	[.XX = ±0.01]		
.XX = ±10	[.XXX = ±0.005]		
ANGLES	∠ = ± 1°		
FRACTIONS	X/X = ±1/64		
INTERPRET GEOMETRIC TOLERANCING PER:			
MATERIAL	6005-T6		
FINISH	See Order Form		
NEXT ASSY	USED ON		
APPLICATION	DO NOT SCALE DRAWING		



TITLE:
2 x 6 Deck Board

SIZE	PART NO.	REV
B	LBD26	A
SCALE: 1:1	WEIGHT: N/A	SHEET 2 OF 3

4

3

2

1

4

3

2

1

B

B

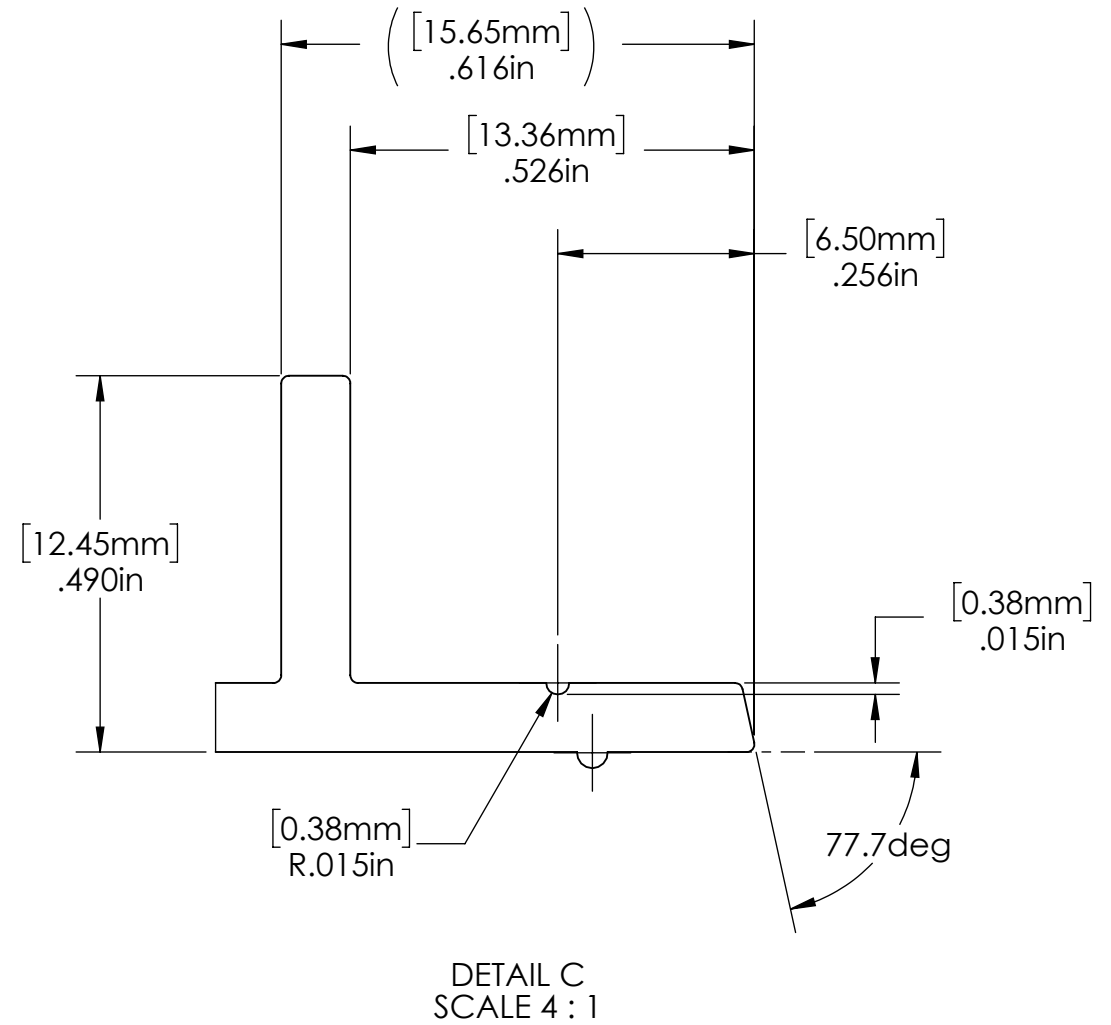
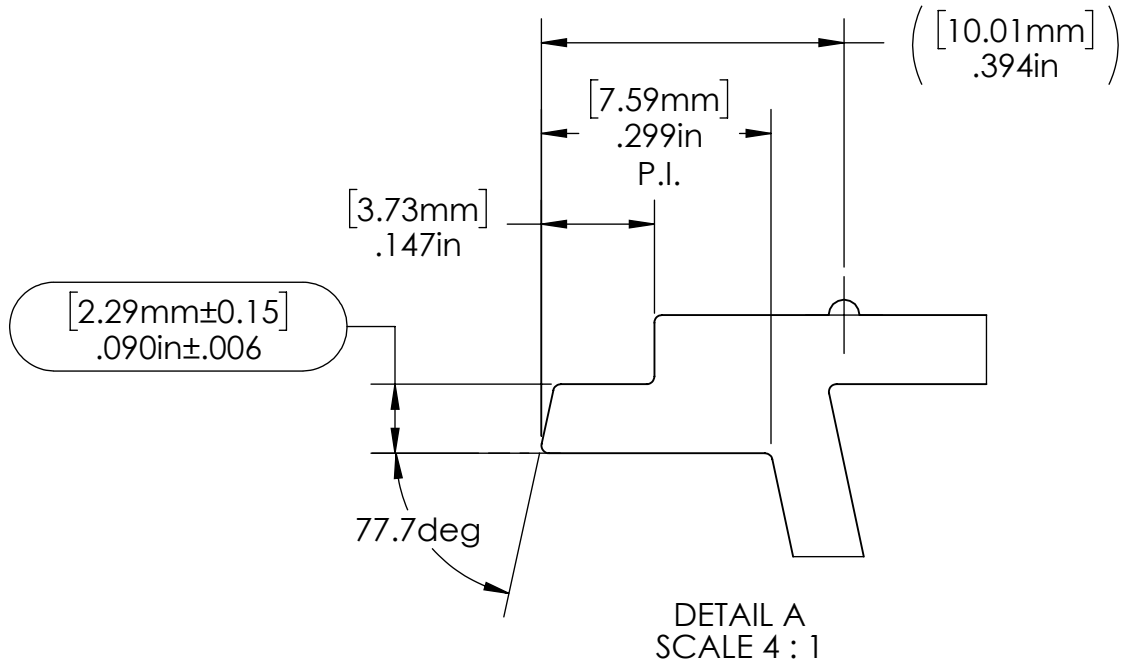

A

A

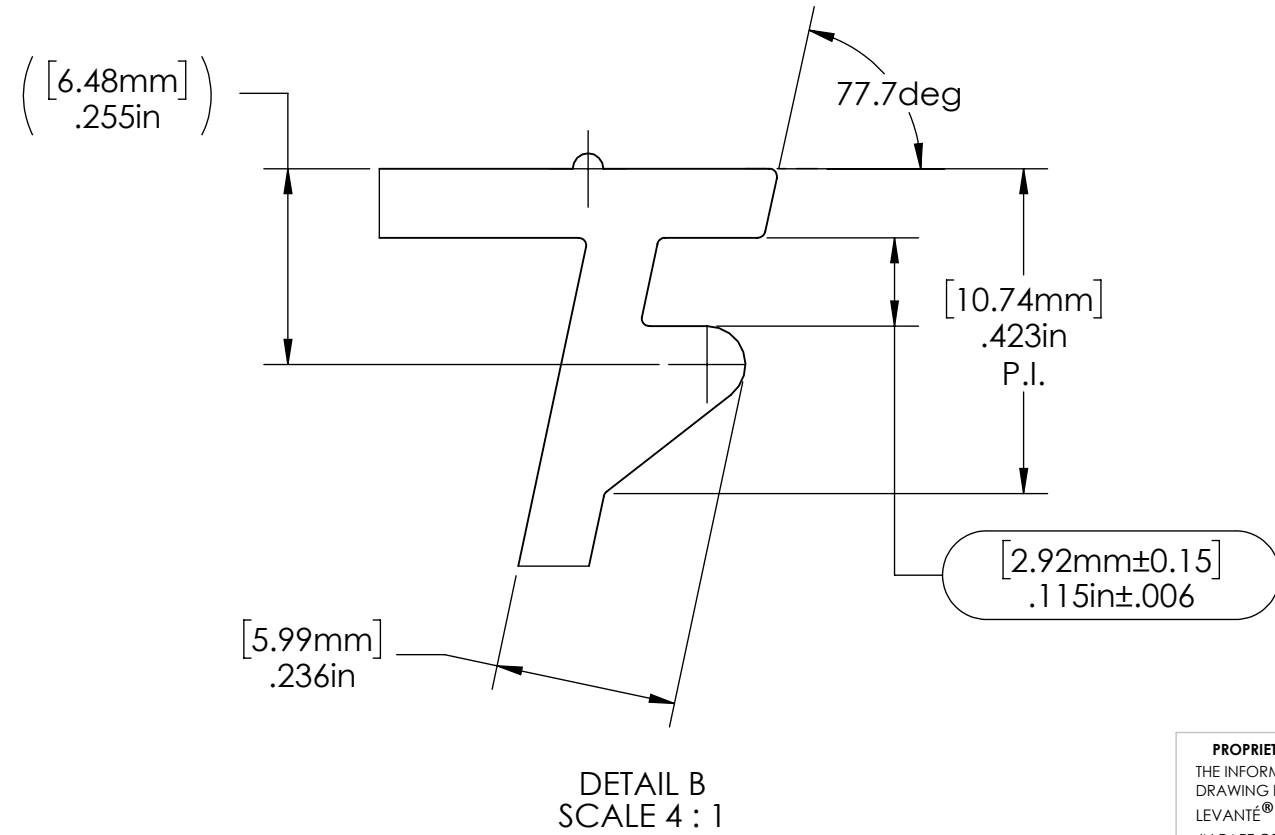

PROPRIETARY AND CONFIDENTIAL
THE INFORMATION CONTAINED IN THIS DRAWING IS THE SOLE PROPERTY OF LEVANTÉ® LLC. ANY REPRODUCTION IN PART OR AS A WHOLE WITHOUT THE WRITTEN PERMISSION OF LEVANTÉ® LLC IS PROHIBITED.

UNLESS OTHERWISE SPECIFIED: DIMENSIONS ARE IN INCHES [MM] TOLERANCES:		NAME	DATE
MILLIMETERS	INCHES	GVP	9/8/2023
X = ±1	[.X = ±0.1]	DRAWN	
.X = ±.20	[.XX = ±0.01]	CHECKED	
.XX = ±10	[.XXX = ±0.005]	ENG APPR.	
ANGLES	∠ = ± 1°	MFG APPR.	
FRACTIONS	X/X = ±1/64	Q.A.	
INTERPRET GEOMETRIC TOLERANCING PER:		COMMENTS:	
MATERIAL	6005-T6		
FINISH	See Order Form		
NEXT ASSY	USED ON		
APPLICATION	DO NOT SCALE DRAWING		



TITLE: 2 x 6 Deck Board		
SIZE	PART NO.	REV
B	LBD26	A
SCALE: 1:1	WEIGHT: N/A	SHEET 3 OF 3

4

3

2

1